

Introduced by: _____

ORDINANCE NO. _____

AN ORDINANCE OF THE CITY OF PASADENA AMENDING VARIOUS SECTIONS OF TITLE 17 (ZONING CODE) OF THE CITY OF PASADENA MUNICIPAL CODE TO IMPLEMENT THE LINCOLN AVENUE SPECIFIC PLAN UPDATE, AND AMENDING THE OFFICIAL ZONING MAP ESTABLISHED BY THE ZONING CODE, CHAPTER 17.20, SECTION 17.20.020 TO MODIFY THE BOUNDARIES OF THE LINCOLN AVENUE SPECIFIC PLAN, REDESIGNATE ZONES WITHIN THE SPECIFIC PLAN AREA, AND REDESIGNATE ZONES FOR PARCELS LOCATED OUTSIDE OF THE SPECIFIC PLAN AREA

The People of the City of Pasadena ordain as follows:

SECTION 1. This ordinance, due to its length and corresponding cost of publication, will be published by title and summary as permitted in Section 508 of the Pasadena City Charter. The approved summary of this ordinance is as follows:

“Summary

This proposed ordinance will amend various sections of Title 17 (Zoning Code) of the City of Pasadena Municipal Code to implement the Lincoln Avenue Specific Plan Update, as shown in Exhibits 1 and 2, attached to the full text of the ordinance and on file in the City Clerk’s Office. This proposed ordinance further amends the official Zoning Map of the City of Pasadena to implement the Lincoln Avenue Specific Plan Update, including modifying the boundaries of the Lincoln Avenue Specific Plan, removing from the specific plan and reclassifying parcels located outside of the specific plan area, and reclassifying parcels remaining within the specific plan area. Changes to

the Lincoln Avenue Specific Plan boundary and zoning designations are shown as Exhibit 3, attached to the full text of the ordinance and on file in the City Clerk's Office.

Ordinance No. _____ shall take effect 30 days from its publication."

SECTION 2. Pasadena Municipal Code, Title 17, Article 2, Chapters 17.21 (Development and Land Use Approval Requirements) and 17.22 (Residential Zoning Districts); Article 4, Chapters 17.40 (General Property Development and Use Standards), 17.43 (Density Bonus, Waivers and Incentives), 17.44 (Landscaping), 17.46 (Parking and Loading), and 17.48 (Signs); Article 5, Chapter 17.50 (Standards for Specific Land Uses); and Article 8, Chapter 17.80 (Glossary of Specialized Terms and Land Use Types) are amended as shown in Exhibit 1, attached hereto and incorporated by reference.

SECTION 3. Pasadena Municipal Code, Title 17, Article 3, Chapter 17.37 (Lincoln Avenue Specific Plan) is repealed in its entirety and is replaced as shown in Exhibit 2, attached hereto and incorporated by reference.

SECTION 4. The official Zoning Map of the City of Pasadena as established by Pasadena Municipal Code Section 17.20.020 is amended by modifying the boundaries of certain zoning districts established therein as follows:

Reclassifying parcels that are now located outside of the specific plan area at 459, 460, and 462 Anderson Place from LASP-RM-16 to RM-16 and 1040 Lincoln Avenue from LASP-CG-1 to CG; removing RS-6 zoned parcels along Anderson Place, RS-6 zoned parcels south of Hammond Street, and PD-4 zoned parcels from the

specific plan boundaries; and reclassifying parcels remaining within the specific plan area from LASP-CG-1 to LA-CG, LASP-CG-2 to LA-CF, LASP-RM-16 to LA-RM-16, LASP-CL to LASP-MU-N for parcels located south of the I-210 Freeway, and LASP-CL to LA-CL for parcels located north of the I-210 Freeway. These modifications are shown on Exhibit 3, attached hereto and incorporated herein by reference.

SECTION 5. The City Clerk shall certify the adoption of this ordinance and shall cause this ordinance to be published by title and summary.

SECTION 6. This ordinance shall take effect 30 days from its publication.

Signed and approved this _____ day of _____, 2022.

Victor M. Gordo
Mayor of the City of Pasadena

I HEREBY CERTIFY that the foregoing ordinance was adopted by the City Council of the City of Pasadena at its meeting held this ___ day of _____ 2022, by the following vote:

AYES:

NOES:

ABSENT:

ABSTAIN:

Date Published:

Mark Jomsky
City Clerk

APPROVED AS TO FORM:

/s/ Theresa Fuentes
Theresa E. Fuentes
Assistant City Attorney

EXHIBIT 1

Pasadena Municipal Code, Title 17, Article 2, Chapter 17.21, Section 17.21.030.A (Allowable land uses) is amended as follows:

“A. **Allowable land uses.** The uses of land allowed by this Zoning Code in each zoning district are listed in Tables 2-2, 2-5, 2-7, 3-1, 3-3, 3-5, 3-6, 3-13, 3-14, 3-16, and 3-18, or in [Article 3](#) (Specific Plans), together with the type of land use permit required for each use.”

(The remainder of Section 17.21.030.A shall remain unchanged.)

Pasadena Municipal Code, Title 17, Article 2, Chapter 17.22, Section 17.22.040 (RS and RM-12 Residential Districts General Development Standards) is amended as follows:

“Subdivisions, new land uses and structures, and alterations to existing land uses and structures, shall be designed, constructed, and established in compliance with the requirements in Table 2-3, in addition those in [Section 17.22.050](#) (RS and RM-12 District Additional Development Standards), and the applicable standards (e.g., landscaping, parking and loading, etc.) in [Article 4](#) (Site Planning and General Development Standards). Zones within an adopted Specific Plan shall be subject to the requirements of this section unless expressly superseded by the applicable adopted Specific Plan in [Article 3](#) (Specific Plans).”

(The remainder of Section 17.22.040 shall remain unchanged.)

Pasadena Municipal Code, Title 17, Article 2, Chapter 17.22, Section 17.22.060 (RM District General Development Standards) is amended as follows:

“Subdivisions, new land uses and structures, and alterations to existing land uses and structures, shall be designed, constructed, and established in compliance with the requirements in Table 2-4, in addition to those in [Section 17.22.070](#) (RM District Additional Development Standards), [17.22.080](#) (RM District Garden Requirements), and the applicable standards (e.g., landscaping, parking and loading, etc.) in [Article 4](#) (Site Planning and General Development Standards). Principal and accessory structures shall meet the development standards unless otherwise modified in this Zoning Ordinance. These standards are commonly known as the City of Gardens standards. Zones within an adopted Specific Plan shall be subject to the requirements of this section unless expressly superseded by the applicable adopted Specific Plan in [Article 3](#) (Specific Plans).”

(The remainder of Section 17.22.060 shall remain unchanged.)

Pasadena Municipal Code, Title 17, Article 2, Chapter 17.22, Section 17.22.070 (RM District Additional Development Standards) is amended as follows:

“The provisions of this Section apply to proposed development and new land uses in the RM 16, RM 32, and RM-48 zoning districts in addition to the other applicable requirements of this Chapter, and those in [Article 4](#) (Site Planning and General Development Standards). Zones within an adopted Specific Plan shall be subject to the requirements of this section unless expressly superseded by the applicable adopted Specific Plan in [Article 3](#) (Specific Plans).”

(The remainder of Section 17.22.070 shall remain unchanged.)

Pasadena Municipal Code, Title 17, Article 2, Chapter 17.22, Section 17.22.080 (RM District Garden Requirements) is amended as follows:

“The presence of gardens and landscaped areas creates the ambiance of Pasadena more than any other factor. Neighborhood character and quality depend on the coherence, embellishment, and visibility of courts and gardens, on the size and consistency of front yards, and on the frequency and uniformity of street trees. Mandatory requirements regulating the size and configuration of yards and gardens are therefore a central feature of these provisions. RM zones within an adopted Specific Plan shall be subject to the requirements of this section unless expressly superseded by the applicable adopted Specific Plan in [Article 3](#) (Specific Plans).”

(The remainder of Section 17.22.080 shall remain unchanged.)

Pasadena Municipal Code, Title 17, Article 4, Chapter 17.40, Section 17.40.060.B (Maximum height of structures) is amended as follows:

“B. **Maximum height of structures.** The height of each structure shall not exceed the height limit established for the applicable zoning district by [Article 2](#) (Zoning Districts and Allowable Land Uses), other provisions of this Article, [Article 5](#) (Standards for Specific Land Uses), by any height limit (HL) overlay zone (Section 17.16.040), or adopted Specific Plan in [Article 3](#) (Specific Plans), except as otherwise provided by this Section. Where the provisions of this Section conflict with an adopted Specific Plan, the Specific Plan shall control.”

Pasadena Municipal Code, Title 17, Article 4, Chapter 17.40, Section 17.40.070.C (Special

hours for truck loading, unloading, and trash pick-up) is amended as follows:

- “C. **Special hours for truck loading, unloading, and trash pick-up.** In the CD, CG, CL, CO, and IG zoning districts and within the commercial, industrial and mixed-use districts of specific plan areas, truck loading, unloading, and trash pick-up for any use that is located within 300 feet of a residential zoning district is allowed only between the hours of 7:00 a.m. to 9:00 p.m., Monday through Friday, and between 9:00 a.m. to 5:00 p.m. on Saturdays. No truck loading, unloading, or trash pick-up is allowed on Sundays.”

Pasadena Municipal Code, Title 17, Article 4, Chapter 17.40, Section 17.40.160.B (Setback requirements) is amended as follows:

“B. **Setback requirements.**

1. **All structures.**

- a. All structures shall comply with the setback requirements of the applicable zoning districts established by [Article 2](#) (Zoning Districts and Allowable Land Uses) or [Article 3](#) (Specific Plans), with the requirements of this Section, and other setback requirements established by this Article and/or [Article 5](#) (Standards for Specific Land Uses).
- b. Each required setback shall be maintained open and unobstructed from the ground upward, except for trees, other plant materials, and the storage of City-provided refuse containers in single-family side or rear setbacks, and except as provided by Subsection E. (Setback and encroachment plane exceptions, allowed projections) below.
- c. Where the provisions of this Section conflict with an adopted Specific Plan, the Specific Plan shall control.

2. **Commercial and industrial districts abutting residential zoning**

districts. In the commercial and industrial zoning districts, except as regulated by an adopted Specific Plan in [Article 3](#) (Specific Plans), a 15-foot side and/or rear setback shall be provided adjacent to any abutting residential zoning district. This setback requirement shall not apply along a property line that abuts a parking overlay property (PK) that is used for parking. Single-family residential projects shall meet the rear setback requirements of the RS-6

district, two units on a lot shall meet the requirements of the RM-12 district and three or more units shall meet the setback requirements for multi-family districts (City of Gardens requirements - [17.22.060](#)).”

Pasadena Municipal Code, Title 17, Article 4, Chapter 17.40, Section 17.40.160.C (Measurement of setbacks) is amended as follows:

“C. **Measurement of setbacks.** The following setbacks shall be measured from each exterior wall of a structure, to define a setback line parallel to the adjacent property line. Figure 4-6 shows the location of each type of setback, and the points from which they are measured. Setbacks may be otherwise regulated by an adopted Specific Plan in [Article 3](#) (Specific Plans). Where the provisions of this Section conflict with an adopted Specific Plan, the Specific Plan shall control.”

(The remainder of Section 17.40.160.C shall remain unchanged.)

Pasadena Municipal Code, Title 17, Article 4, Chapter 17.40, Section 17.40.160.D (Encroachment plane requirements) is amended as follows:

“D. **Encroachment plane requirements.** Proposed structures shall comply with the following encroachment plane requirements, or as otherwise regulated by an adopted Specific Plan in [Article 3](#) (Specific Plans), in addition to the minimum setback requirements of this Section except as otherwise provided by Subsection E. (Setback and encroachment plane exceptions, allowed projections) below. Where the provisions of this Section conflict with an adopted Specific Plan, the Specific Plan shall control. In addition to the minimum setback requirements of the applicable zoning district and as defined in Subsection C., above, a main structure within:”

(The remainder of Section 17.40.160.D shall remain unchanged.)

Pasadena Municipal Code, Title 17, Article 4, Chapter 17.40, Section 17.40.160.F (Limitations on the use of setbacks) is amended as follows:

“F. **Limitations on the use of setbacks.** A required setback shall only be used in compliance with the following requirements, or as regulated by an adopted Specific Plan in [Article 3](#) (Specific Plans). Where the provisions of this Section conflict with an adopted Specific Plan, the Specific Plan shall control.

1. **Storage.** No required setback shall be used for the storage of:

- a. Junk, inoperable vehicles, scrap, or similar material; or
 - b. Building materials, except during on-site construction, in compliance with a valid Building Permit.
2. **Parking.** Parking is allowable within a required setback only in compliance with [Section 17.46.020](#) Basic Requirements for Off-Street Parking and Loading) or as regulated by an adopted Specific Plan in [Article 3](#) (Specific Plans).”

(The remainder of Section 17.40.160.F shall remain unchanged.)

Pasadena Municipal Code, Title 17, Article 4, Chapter 17.40, Section 17.40.180.B.4 (Nonresidential zoning districts) is amended as follows:

- “4. **Nonresidential zoning districts.** The maximum height of a wall or fence within the commercial, mixed-use, and industrial zoning districts, including the CD, shall be as follows unless otherwise modified or regulated by an adopted Specific Plan:”

(The remainder of Section 17.40.180.B.4 shall remain unchanged.)

Pasadena Municipal Code, Title 17, Article 4, Chapter 17.40, Section 17.40.190.A (Nonresidential development) is amended as follows:

- “A. **Nonresidential and mixed-use development.** All utility facilities shall be installed underground within the site.”

Pasadena Municipal Code, Title 17, Article 4, Chapter 17.43, Section 17.43.060.A (Waiver of Development Standards) is amended as follows:

- “A. **Waiver of Development Standards.** If compliance with a development standard would physically preclude construction of a residential or mixed-use project utilizing a density bonus, and concession or incentive, in compliance with this Chapter, the applicant may submit a proposal for waiver or reduction of the development standard. Projects that utilize a waiver of development standards shall not be permitted to utilize the Modulation alternative compliance process under an adopted Specific Plan.”

Pasadena Municipal Code, Title 17, Article 4, Chapter 17.44, Section 17.44.060.C.1 (Landscaping of setbacks) is amended as follows:

“1. **Landscaping of setbacks.** All setback and open space areas required by this Zoning Code shall be landscaped, except where a required setback is occupied by a sidewalk or driveway, or where a required setback is screened from public view and it is determined by the Zoning Administrator that landscaping is not necessary to fulfill the purposes of this Section, unless otherwise regulated by an adopted Specific Plan in [Article 3](#) (Specific Plans).”

Pasadena Municipal Code, Title 17, Article 4, Chapter 17.46, Section 17.46.020.A (Applicability) is amended as follows:

“A. **Applicability.** Every use, including a change or expansion of a use or structure, shall have appropriately maintained off-street parking and loading spaces or areas in compliance with the regulations identified in this Chapter, or as regulated by an adopted specific plan in [Article 3](#) (Specific Plans). A use shall not be commenced and structures shall not be occupied until improvements required by this Chapter are satisfactorily completed. Where the provisions of this Section conflict with an adopted Specific Plan, the Specific Plan shall control.”

Pasadena Municipal Code, Title 17, Article 4, Chapter 17.48, Section 17.48.090.D (Signs allowed in the CL, CG, IG zoning district) is amended as follows:

“D. **Signs allowed in the CL, CG, CF, IG, MU zoning districts, and other commercial, industrial, and mixed-use zoning districts in other Specific Plans.**”

TABLE 4-21 - CL, CG, CF, IG, and MU ZONING DISTRICTS, AND ALL OTHER COMMERCIAL, INDUSTRIAL, AND MIXED-USE ZONING DISTRICTS IN OTHER ADOPTED SPECIFIC PLANS SIGN STANDARDS

Sign Class	Allowed Sign Types	Maximum Number	Maximum Sign Area	Maximum Sign Height	Location Requirements	Lighting Allowed?	Additional Requirements”
------------	--------------------	----------------	-------------------	---------------------	-----------------------	-------------------	--------------------------

(The remainder of Section 17.48.090.D shall remain unchanged.)

Pasadena Municipal Code, Title 17, Article 5, Chapter 17.50, Section 17.50.020 (Applicability) is amended as follows:

“The land uses and activities covered by this Chapter shall comply with the provisions of the Sections applicable to the specific use, in addition to all other applicable provisions of this Zoning Code.

- A. **Where allowed.** The uses that are subject to the standards in this Chapter shall be located in compliance with the requirements of [Article 2](#) (Zoning Districts and Allowable Land Uses) and [Article 3](#) (Specific Plans).
- B. **Land use permit requirements.** The uses that are subject to the standards in the Chapter shall be authorized by the land use permit required by [Article 2](#) and [Article 3](#), except where a land use permit is established by this Chapter for a specific use.
- C. **Development standards.** The standards for specific uses in this Chapter supplement, and are required in addition to, those in Articles 2 (Zoning Districts and Allowable Land Uses), 3 (Specific Plans), and 4 (Site Planning and General Development Standards). In the event of any conflict between the requirements of this Chapter and those of Articles 2, ~~3~~, or 4, the requirements of this Chapter shall control. [Article 3](#) (Specific Plans) may include additional applicable development standards by use. Where [Article 3](#) (Specific Plan) is silent the requirements of this Chapter shall control; where the provisions of this Section conflict with an adopted Specific Plan, the Specific Plan shall control.”

Pasadena Municipal Code, Title 17, Article 5, Chapter 17.50, Section 17.50.160.A (Purpose) is amended as follows:

- A. **Purpose and applicability.** The purpose of this Section is to ensure compatibility between the different land uses (e.g., residential and commercial) operating within a mixed-use project. The requirements of this Chapter shall apply to mixed-use projects not regulated by [Article 3](#) (Specific Plans). All standards for development of mixed-use projects in an adopted Specific Plan area shall be regulated by the applicable specific plan.”

Pasadena Municipal Code, Title 17, Article 5, Chapter 17.50, Section 17.50.350.A (Applicability) is amended as follows:

“A. **Applicability.** The development standards of this Section shall apply to the following:

1. Residential development projects utilizing a density greater than 48 dwelling units per acre.
2. Development projects located within the CD zoning district.
3. Development projects located outside a Specific Plan area but designated for transit-oriented development around light-rail stations.”

Pasadena Municipal Code, Title 17, Article 5, Chapter 17.50, Section 17.50.370.A (Applicability) is amended as follows:

“A. **Applicability.** This Section provides standards for work/live and artists lofts/studios, including the reuse of existing nonresidential structures to accommodate work/live opportunities. Work/live quarters are especially intended for the use and occupation of artisans, artists, and individuals practicing similar professions as well as their families. Where [Article 3](#) (Specific Plan) is silent the requirements of this Chapter shall control; where the provisions of this Section conflict with an adopted Specific Plan, the Specific Plan shall control.”

Pasadena Municipal Code, Title 17, Article 8, Chapter 17.80, Section 17.80.020 (Definitions) is amended to add the following definitions in their proper alphabetical order:

“Accessory Tasting Room (land use).

The sale of beverages manufactured on the premises for on-site or off-site consumption. It includes establishments such as breweries, wineries, and distilleries that offer tastings and sales of alcohol beverages in accordance with a license issued by the California Department of Alcoholic Beverage Control.

Alcohol Beverage Manufacturing (land use).

A use where manufacturing of beer, wine, or other alcohol beverages are produced and prepared. Sale for off-site consumption permitted.

Custom Manufacturing / Artisan Production (land use).

A small-scale use limited to a maximum gross floor area of 15,000 square feet that involves the assembly, compounding, design, development, evaluation,

manufacturing, processing, packaging, or treatment of components into products and conducted within enclosed buildings. Uses requiring state or federal emissions permits are excluded. Truck trips are limited to maximum of 10 per day. Accessory uses that support the primary use may comprise up to 25% of the gross floor area. Accessory uses may include, but are not limited to, outdoor dining, on-site food and beverage tastings, and retail.”

(The remainder of Section 17.80.020 shall remain unchanged.)

EXHIBIT 2

Chapter 17.37 - Lincoln Avenue Specific Plan

17.37.010 - Purpose of Chapter

This Chapter lists the land uses that may be allowed within the zoning districts established by the Lincoln Avenue Specific Plan (LASP), determines the type of land use permit/approval required for each use, and provides comprehensive design and development standards for all projects.

17.37.020 - Applicability

The applicability of the LASP land use regulations and development standards are organized by zoning district and plan chapters (Table LASP-1). Where the standards do not apply, the relevant section of Pasadena Municipal Code (PMC) is referenced. In PS, development shall be subject to a Conditional Use Permit or Master Plan per [Section 17.26](#). Note that Vision, Goals & Policies and Public Realm standards apply throughout the plan area.

Table LASP-1: Applicability

Zone	Specific Plan Chapters			
	Vision, Goals & Policies	Zoning & Land Use	Public Realm Standards	Development Standards
LA-CG	✓	✓	✓	✓
LA-CL	✓	✓	✓	✓
LA-CF	✓	✓	✓	✓
LA-MU-N	✓	✓	✓	✓
LA-RM-16	✓	✓	✓	✓
PS	✓	17.26	✓	17.26

17.37.030 - Zoning Districts

The purpose of the LASP zoning districts (Figure LASP-1) is to implement the Lincoln Avenue Specific Plan by repurposing the Lincoln Avenue corridor from an industrial and limited commercial area into a vibrant neighborhood-oriented district, with new housing options and a complement of local-serving retail and service businesses, office spaces

and community uses, all tied together with public improvements that create a vibrant and enjoyable pedestrian environment.

A. LA-CG (Commercial General)

- Foster a pedestrian-oriented neighborhood core
- Accommodate a diverse range of retail and office businesses that people can walk to for shopping, dining, personal and community services, and social activities

B. LA-CL (Commercial Limited)

- Provide opportunities for limited commercial uses that serve as a transitional buffer between residential uses and the freeway
- Allow future uses that are compatible with neighboring homes

C. LA-CF (Commercial Flex)

- Allow a wide range of commercial and research & development uses
- Provide flexibility for the city's burgeoning innovation and production industries
- Restrict heavy industrial uses that may be inappropriate next to residential uses

D. LA-MU-N (Mixed-Use Neighborhood)

- Allow pedestrian-oriented ground floor commercial uses
- Support projects that are entirely commercial, entirely residential, or a mix of the two, integrated either horizontally or vertically

E. LA-RM-16 (Residential Multi-Family)

- Allow a variety of multi-family and compatible residential uses of an appropriate scale

F. PS (Public-Semipublic)

- Accommodate institutional uses that may not be appropriate in other zoning districts

Figure LASP-1: Zoning Districts

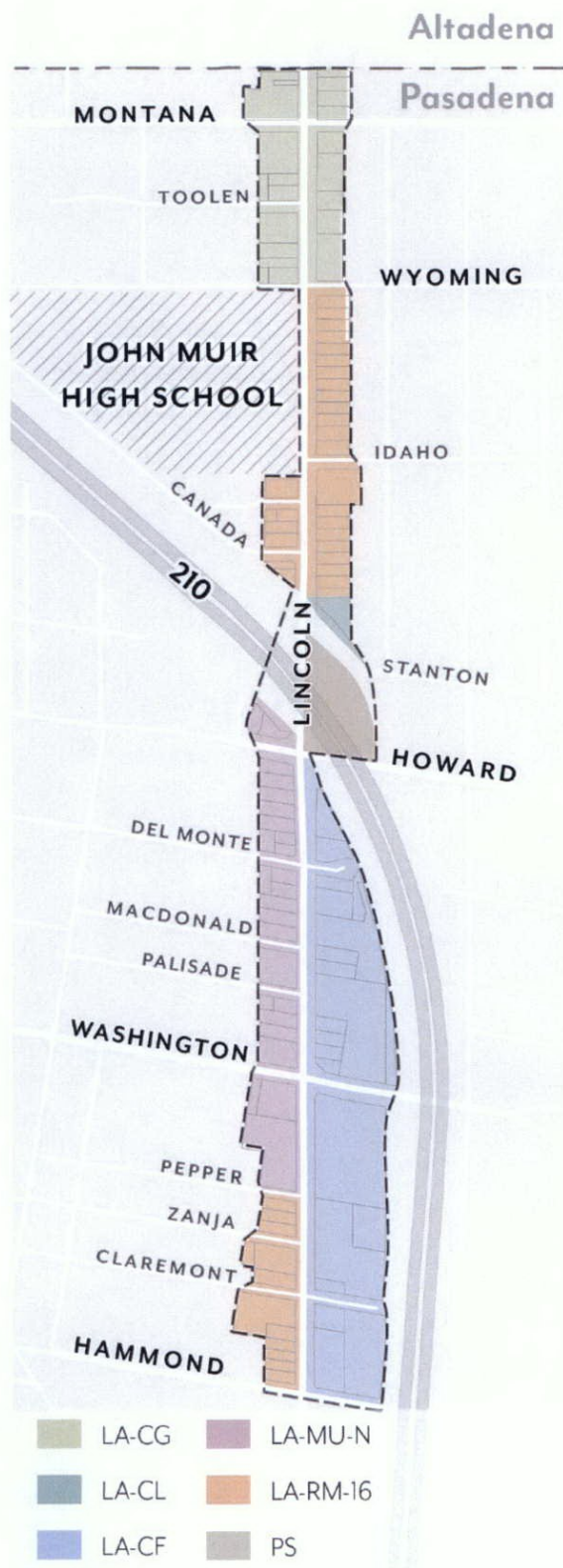

17.37.040 - Allowable Land Uses

- A. **Definitions.** Definitions of specific land uses are found in Section 17.80.020, except those listed in Table LASP-2 footnotes.
- B. **Permit Requirements.** Table LASP-2 identifies the uses of land allowed, the land use permit required to establish each use, and limitations that may apply for a particular use.
- C. **Standards for Specific Land Uses.** Additional standards may apply to specific land uses; refer to the Section noted in Table LASP-2.
1. [Section 17.50.160](#) shall not apply to Mixed-Use Projects.
 2. [Section 17.50.350](#) shall not apply to Multi-Family Housing.
- D. **Upper Floors.** In LA-MU-N, stories above the ground floor are limited to residential uses; non-residential uses are prohibited.
- E. **Alcohol Sales.** The sale of alcohol is conditionally permitted only as an accessory use to the following primary uses where permitted.
1. On-site consumption: accessory use to a restaurant or alcohol beverage manufacturing (i.e. brewery, distillery tasting room).
 2. Off-site consumption: accessory use to retail food sales in commercial spaces >15,000 square feet; floor space for alcohol shall be no more than 5 percent of the total floor area, including both sales and storage.
- F. **Major Construction.** For all non-residential uses with a gross floor area of 25,000 square feet or greater, a Conditional Use Permit shall be required per [Section 17.61.050.J.2](#).
- G. **Prohibited Uses.** Those uses not listed in Table LASP-2 are prohibited by this Specific Plan, except as otherwise provided by [Section 17.21.030.A](#).
1. Drive-throughs associated with any use are prohibited.
- H. **Nonconforming Uses.** Existing uses which are made nonconforming by this Specific Plan shall be subject to [Section 17.71](#).

Table LASP-2: Allowable Land Uses

Symbol	Description	Section				
P	Permitted use, Code Compliance Certificate required.	17.61.020				
MC	Conditional use, Minor Conditional Use Permit required.	17.61.050				
C	Conditional use, Conditional Use Permit required.					
E	Conditional use, Expressive Use Permit required.	17.61.060				
TUP	Temporary use, Temporary Use Permit required.	17.61.040				
—	Use not allowed.					
ZONING DISTRICT LAND USES AND PERMIT REQUIREMENTS						
Land Use ¹	Permit Requirement					Section / Notes
	LA-CG	LA-CL	LA-CF	LA-MU-N	LA-RM-16	
RESIDENTIAL USES						
Accessory Dwelling Unit	—	—	—	P	P	17.50.275
Home Occupations	—	—	—	P	P	17.50.110
Mixed-Use Projects	—	—	—	P	—	
Multi-Family Housing	—	—	—	P	P	
Residential Accessory Uses and Structures	—	—	—	P	P	17.50.250
Residential Care, Limited	—	—	—	P	P	
Supportive Housing	—	—	—	P	P	
Transitional Housing ²	—	—	—	P	P	
COMMERCIAL USES						
RECREATION, EDUCATION & PUBLIC ASSEMBLY USES						
Clubs, Lodges, Private Meeting Halls	C	C	C	C	C	
Colleges, Nontraditional Campus Setting	P	P	P	P	—	
Commercial Entertainment	E	—	E	E	—	17.50.130
Commercial Recreation, Indoor	P	—	P	P	—	
Commercial Recreation, Outdoor	C	—	C	—	—	
Cultural Institutions	P	P	P	P	C	
Electronic Game Centers	C	—	C	C	—	17.50.100
Park and Recreation Facilities	P	P	P	P	P	
Religious Facilities	C	C	C	C	C	17.50.230
with Columbarium	MC	MC	MC	MC	—	
with Temporary Homeless Shelter	C	C	C	C	—	
Schools, Public and Private	C	C	C	C	C	17.50.270
Schools, Specialized Education and Training	P	P	P	P	—	
OFFICE, PROFESSIONAL & BUSINESS SUPPORT USES						

Exhibit 2

Automated Teller Machines (ATMs)	P	P	P	P	—	17.50.060
Banks and Financial Services	P	P	P	P	P	
with Walk-Up Services	P	P	P	P	—	17.50.060
Business Support Services	P	P	P	P	—	
Offices, Accessory	P	P	P	P	—	
Offices, Administrative Business Professional	P	P	P	P	—	
Offices, Government	P	P	P	P	—	
Offices, Medical	P	P	P	P	—	
Offices, Research and Development	P	P	P	P	—	17.50.240
Work/Live Units	P	—	P	P	—	17.50.370
RETAIL SALES						
Alcohol Sales, Beer and Wine	C	C	C	C	—	17.37.040.E, 17.50.040
Alcohol Sales, Full Alcohol	C	C	C	C	—	
Animal Retail Sales	P	—	—	—	—	
Commercial Nurseries	C	C	C	C	—	17.50.180
Convenience Stores	C	C	C	C	—	
Food Sales	P	—	P	P	—	
Restaurants, Fast Food	P	—	P	P	—	17.50.260
Restaurants, Formula Fast Food	P	—	P	P	—	
Restaurants	P	P	P	P	—	
with Limited Live Entertainment	P	—	P	P	—	
with Walk-Up Window	MC	MC	MC	MC	—	
Retail Sales	P	P	P	P	—	Retail stores shall not exceed 40,000 square feet in size.
Service Stations	C	—	—	—	—	17.50.290
SERVICES						
Adult Day Care, Limited	P	P	P	P	P	
Animal Services, Grooming	P	P	P	P	—	
Catering Services	P	P	P	P	—	
Charitable Institutions	P	P	P	P	—	
Child Day Care Centers	C	C	C	C	C	17.50.080
Child Day Care, Large	—	P	—	P	P	
Child Day Care, Small	—	P	—	P	P	
Laboratories	P	MC	P	MC	—	
Maintenance and Repair Services	P	—	P	P	—	
Massage Establishments	C	—	—	C	—	17.50.155
Mortuaries / Funeral Homes	C	—	C	—	—	
Neighborhood Gardens	P	P	P	P	P	
Personal Improvement Services	P	P	P	P	—	
Personal Services	P	P	P	P	—	
Printing and Publishing, Limited	P	P	P	P	—	
Public Safety Facilities	C	C	C	C	C	

INDUSTRY, MANUFACTURING & PROCESSING						
Alcohol Beverage Manufacturing ³	—	—	C	—	—	17.37.040.E, 17.50.040
with Accessory Tasting Room ⁴	—	—	C	—	—	
Custom Manufacturing / Artisan Production ⁵	—	—	P	—	—	
Recycling Centers, Small	—	—	MC	—	—	17.50.220
Research and Development, Non-Offices	C	C	P	—	—	17.50.240
TRANSPORTATION, COMMUNICATIONS, AND UTILITY USES						
Accessory Antenna Arrays	P	P	P	P	—	
Commercial Off-Street Parking	C	C	C	—	—	
Communications Facilities	C	C	C	C	—	
Transportation Terminals	C	C	C	C	—	
Utilities, Major	C	C	C	C	C	
Utilities, Minor	P	P	P	P	P	
Wireless Telecom Facilities, Major	C	C	C	C	—	17.50.310
Wireless Telecom Facilities, Minor	MC	MC	MC	MC	—	
Wireless Telecom Facilities, SCL	P	P	P	P	—	
TEMPORARY USES						
Filming, Long-term	C	C	C	C	C	
Filming, Short-term	P	P	P	P	P	
Personal Property Sales	—	—	—	P	P	17.50.190
Seasonal Merchandise Sales	P	P	P	P	—	17.50.180 ; 17.61.050.J
Street Fairs	P	P	P	P	P	
Tents	TUP	TUP	TUP	TUP	TUP	17.50.320
Other Temporary Uses	TUP	TUP	TUP	TUP	TUP	
Notes:						
1 See Section 17.80.020 for definition of the listed land uses, except those listed in footnotes.						
2 The maximum interior or exterior area in which support services are offered or located shall not exceed 250 square feet.						
3 Alcohol Beverage Manufacturing is defined as a use where manufacturing of beer, wine, or other alcohol beverages are produced and prepared. Sale for off-site consumption permitted.						
4 Accessory Tasting Room is defined as the sale of beverages manufactured on the premises for on-site or off-site consumption. It includes establishments such as breweries, wineries, and distilleries that offer tastings and sales of alcohol beverages in accordance with a license issued by the California Department of Alcoholic Beverage Control.						
5 Custom Manufacturing / Artisan Production is defined as a small-scale use limited to a maximum gross floor area of 15,000 square feet that involves the assembly, compounding, design, development, evaluation, manufacturing, processing, packaging, or treatment of components into products and conducted within enclosed buildings. Uses requiring state or federal emissions permits are excluded. Truck trips are limited to maximum of 10 per day. Accessory uses that support the primary use may						

comprise up to 25% of the gross floor area. Accessory uses may include, but are not limited to, outdoor dining, on-site food and beverage tastings, and retail.

17.37.050 - Public Realm Standards

These standards are intended to:

- Ensure a minimum sidewalk width is achieved, appropriate to support future densities, intensities, uses, and pedestrian volumes;
- Enhance pedestrian conditions and improve street tree health through increased landscaping and permeability at sidewalk level;
- Provide sufficient space to support dedicated amenity and walk zones; and
- Increase shade, carbon sequestration, and stormwater capture by allowing adequate space for street trees and parkways.

A. Sidewalks

1. Sidewalk Width

- a. Dimension. Projects shall provide sidewalks that meet the required widths per Figure LASP-2. Where the existing sidewalk right-of-way is less than the required width, the difference shall be provided through a private property dedication.
 - (1) Sidewalks are measured from the Primary Curb Line of each block to the sidewalk line, as illustrated in Figure LASP-3.
 - (2) This area shall be paved for general use to the standards specified by Public Works, except for landscaped parkways per Section 17.37.050.B.
 - (3) Within the sidewalk width, sidewalk zones shall be provided to the dimensions set in Figure LASP-4.
 - (4) Where the curb deviates (i.e. bulb-outs), exceptions in zone width are allowed and shall be determined by Public Works.
 - (5) Driveways are allowed per Section 17.37.100.B.
- b. Maintenance. Sidewalk improvements shall be installed and maintained by the abutting property owner.

Figure LASP-2: Sidewalk Width

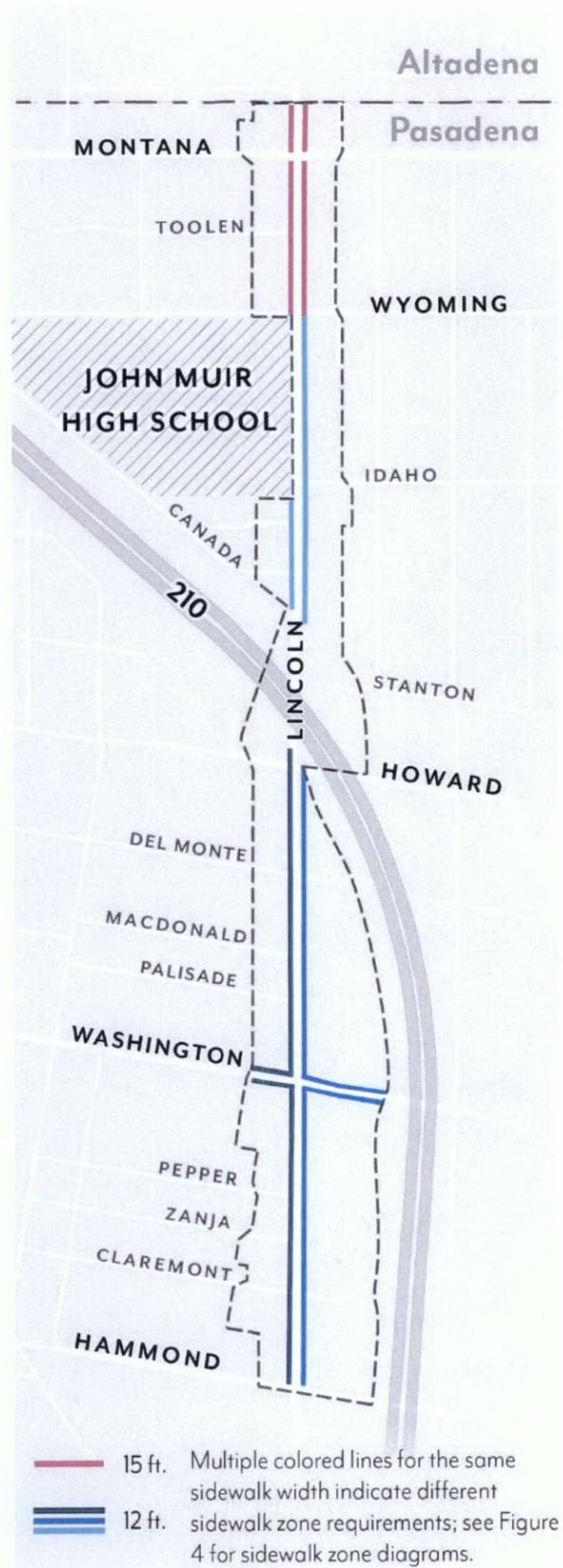

Figure LASP-3: Sidewalk Line

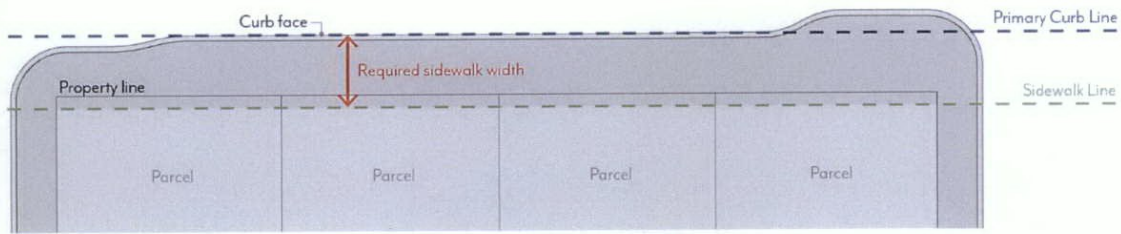

Figure LASP-4: Sidewalk Zones

Diagram 1: 15' Sidewalks



Diagram 2: 12' Sidewalks

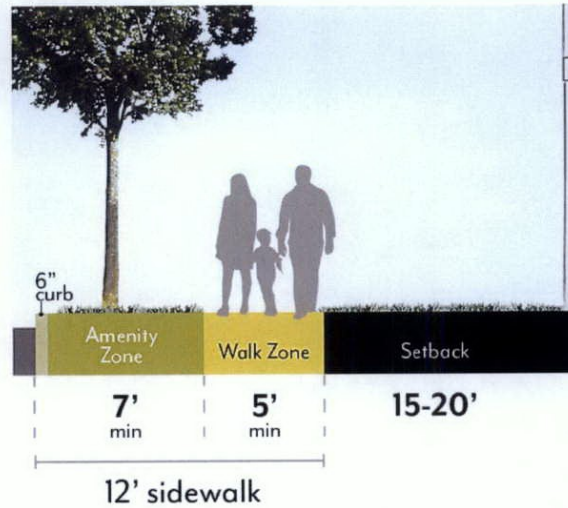

Diagram 1: 12' Sidewalks

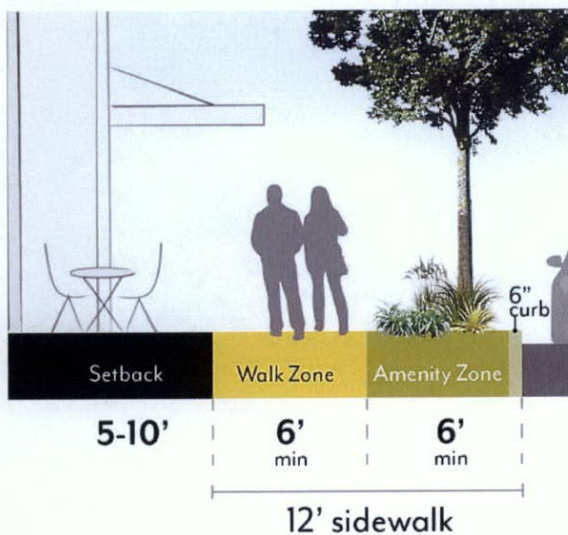

Diagram 2: 12' Sidewalks



2. Sidewalk Zones

- a. Amenity Zone. Sidewalks shall provide an Amenity Zone consistent with the width illustrated in Figure LASP-4, including the curb.
 - (1) Projects shall meet minimum parkway and street tree requirements per Section 17.37.050.B.
 - (2) The following elements are permitted in the Amenity Zone at the discretion of Public Works: paved area for pedestrian mobility, parkways and street trees, seating/furniture, outdoor dining (with a Public Works permit), planters, bicycle parking, bus shelters, and/or other utility facilities including streetlights, signals, meter/sign poles, and pullboxes, etc.
- b. Walk Zone. Sidewalks shall maintain a Walk Zone as a continuous path of travel for pedestrians at the width illustrated in Figure LASP-4. This area shall be free of all furnishings, landscaping, or obstructions.
- c. Frontage Zone. Sidewalks may include a Building Frontage Zone between the Walk Zone and the sidewalk line. A maximum width is illustrated in Figure LASP-4.
 - (1) The following elements are permitted in the Frontage Zone: paved area for pedestrian mobility, seating/furniture, outdoor dining (with a Public Works permit), planters, and/or shade structures per Section 17.37.080.D.

B. Parkways & Street Trees

1. Parkways

- a. Required Parkways. Projects shall include parkways within the Amenity Zone as follows.
 - (1) In LA-RM-16, parkway length shall be no less than 60 percent of street frontage, unless approved by the Director of Public Works.
 - (2) In all other zoning districts, parkway length shall be no less than 30 percent of street frontage, unless approved by the Director of Public Works.

- b. Dimensions. Parkway shall be constructed at the same width as the Amenity Zones illustrated in Figure LASP-4, minus the 6-inch width required for the curb.
 - (1) When street parking is adjacent to the curb, a paved buffer with a minimum width of 18 inches is required, in addition to the 6-inch curb, except where tree grates are adjacent to the curb.
 - (2) Barriers up to 24 inches high, such as low walls or fences, are permitted at the interior edge of the parkway but are not required.
- c. Access Ways. Where on-street parking is permitted, access ways shall be provided at a minimum frequency of one per every 20 feet of continuous parkway.
 - (1) Access ways shall be a minimum of 4 feet in width and provide a firm, uniform walking surface in all weather conditions from the curb to the Walk Zone.
 - (2) The finished surface of access ways shall be in plane with both the adjoining top of curb and sidewalk.
 - (3) Access ways shall be constructed of pavers, concrete, or stabilized decomposed granite.
- d. Planted Area. A minimum of 80 percent of the total required parkway area for a given project shall be comprised of plant material.
 - (1) Permitted materials include groundcovers, turf or turf substitutes, and shrubs or low perennials that are lower than 24 inches in height at full maturity.
 - (2) All plant material shall be native or climate appropriate and have a water use rating of Moderate, Low or Very-Low as defined by Water Use Classification of Landscape Species (WUCOLS) for the region. Plant water use requirements may be relaxed to maximize the efficiency of parkway stormwater capture systems per approval by the Director of Public Works.

- (3) Plants with spines or thorns shall not be planted adjacent to any walkways or curbs.
 - (4) Edible plants are not permitted in parkways.
 - (5) Artificial turf is not permitted in parkways.
 - (6) When removing existing plant material like turf grass from a parkway, there shall be no damage to the street tree roots. Parkway improvements involving excavation within an existing tree's root zone must be consistent with the City's Tree Protection Guidelines. Root pruning, if required and approved by Public Works, must be overseen by a Certified Arborist. Excavation within a tree's root zone must be replanted immediately to prevent the tree roots from exposure and undue harm.
- e. Non-planted Area. A maximum of 20 percent of the parkway area may be organic or inorganic cover.
- (1) Permitted materials include permeable pavers, decomposed granite, gravel, rocks, or mulch. Pavers are not allowed within 3 feet of any public streetlight pole or pull box or other utility facilities.
- f. Stormwater Management. Parkway shall either meet the following basic stormwater standards, or propose a biofiltration planter or swale design based on local conditions per the approval of the Director of Public Works.
- (1) The parkway shall be at the same grade as the adjacent hardscape surface at the outer edge of the parkway and slope at a minimum of 1 percent towards the center of the parkway.
 - (2) For parkways with a width greater than 5 feet, the center 2 feet of the parkway shall be depressed 3 to 4 inches to form a shallow swale to collect sidewalk stormwater. Alternative means of storing runoff, such as gravel sumps within the parkway, may be provided with review authority approval.
- g. Irrigation. Irrigation systems in parkways shall be designed and constructed in a manner that will eliminate surface runoff onto any impermeable surface, public or private, under any condition.

- (1) Design of irrigation systems in parkways shall be in accordance with all local, state, and federal laws and regulations for water conservation.
- (2) Street tree roots shall not be damaged during the irrigation installation process.
- h. Maintenance. Abutting property owner shall maintain the parkway in a condition so as not to endanger persons or property, and not to interfere with the public convenience.

2. Street Trees

- a. Species. Street tree species shall be selected according to the Master Street Tree Plan at the discretion of the Director of Public Works. Trees may be planted within parkways or tree wells.
- b. Spacing. Street trees shall be planted at a spacing of one per 30 feet. Exceptions can be made by the Director of Public Works due to conflicts with street lights, bus shelters, utility boxes, or other street amenities. Closer spacing is encouraged when feasible and when appropriate for the particular tree type.
- c. Well Dimension. Tree well width shall be equivalent to the required Amenity Zone, minus the 6-inch width required for the curb.
 - (1) If a paved buffer zone is required due to adjacent street parking, the tree well width may be reduced to accommodate this buffer strip. The minimum length of a tree well shall be 6 feet.
 - (2) Street trees planted within tree wells must be installed according to the Department of Public Works Tree Planting in Tree Well Standard Plan.
- d. Well Frames. Tree well frames, or tree grates, may be installed according to the Department of Public Works Tree Well Frame Installation Standard.
- e. Expanded Root Zone Cell. Each street tree shall be provided with an uncompacted root zone volume of 800 cubic feet minimum. The root zone volume depth shall be 2 feet minimum and 3 feet maximum.

- (1) Where this root zone volume cannot be provided within the parkway area, an expanded root zone cell volume shall be provided below adjacent pavement using a strategy such as structural soil or a suspended pavement system to provide an uncompacted soil area suitable for tree root growth.
 - (2) The root zone volume per tree requirement may be reduced by 10 percent where two or more trees share a contiguous root zone cell.
- f. Maintenance. All street trees shall be maintained by the Department of Public Works.

17.37.060 - Summary of Development Standards

Table LASP-3 provides abbreviated development and design standards by zoning district for the Specific Plan. Complete standards shall be referenced within Sections 17.37.070-17.37.100.

Table LASP-3: Summary of Development Standards

Standard	LA-CG	LA-CL	LA-CF	LA-MU-N	LA-RM-16
Scale					
Allowable Density					
Dwelling Units per Acre	N/A	N/A	N/A	32	16
Allowable Intensity					
Floor Area Ratio	1.0	1.0	1.0	1.0	N/A
Building Height					
Height	39'	36'	39'	36'	36'
Required Setbacks					
Lincoln Avenue	0-5' for 75% of frontage	15'	5-10' for 75% of frontage	5-10' for 75% of frontage	15-20' for 50% of frontage
Other streets	0-5' for 75% of frontage	None required	5-10' for 50% of frontage	5-10' for 50% of frontage	10'
Adjacent RM/RS	15'	15'	N/A	15' (5' if Res)	5'
Other interiors	None required				5'
Required Stepbacks					

Exhibit 2

All streets	None required			10' deep at 36'	None required	
Adjacent to RS	Figure LASP-11		None required	Figure LASP-11		
Historic Adjacency						
Setbacks & Stepbacks	Modified standards apply to projects adjacent to designated resources					
Required Modulation					PMC 17.22.070	
Length	100'	75'	150'	150'		
Area	25%	25%	25%	25%		
Frontage						
Ground Floor Dimensions						
Height	15' min.	15' min.	15' min.	15' min.	PMC 17.22.070	
Commercial Depth	35' avg.	35' avg.	35' avg.	35' avg.		
Entrances	Section 17.37.080.B					
Minimum Transparency						
Ground Floor	70%	30%	30%	70%		
Overall Façade	30%	15%	15%	30%		
Residential Units	N/A	N/A	N/A	15%		
Required Shade Structures						
Coverage	5-10' for 50% of bldg frontage	None required				
Arcades & Galleries	Section 17.37.080.E					
Required Lighting						
Frequency	Every 30'	None required				
Walls & Fences	Section 17.37.080.G					
Balconies & Roof Decks	Section 17.37.080.H					
Open Space						
Minimum Area	Section 17.37.090.A				PMC 17.22.080	
Non-residential	5% of Non-residential Building Floor Area for projects over 40,000 sf					
Residential	200 sf per studio, 225 sf per 1-bed, 250 sf per 2-bed, 275 sf per 3+bed					
Publicly Accessible	Per Section 17.37.090.A.2 for projects over 80,000 sf in LA-CF; none required otherwise					
Private Open Space	Section 17.37.090.B					

Common Open Space	Section 17.37.090.C				
Publicly Accessible Open Space	N/A	N/A	Section 17.37.090.D	N/A	
Parking					
Minimum Parking	Section 17.37.100.A				
Vehicle Access	Section 17.37.100.B				Section 17.22.070
Layout & Design	Section 17.37.100.C				
Other Applicable Standards¹					
City of Gardens	N/A	N/A	N/A	N/A	Section 17.22.070
General Development	Section 17.40				
Inclusionary Housing	Section 17.42				
Density Bonus	Section 17.43				
Landscaping	Section 17.44				
Parking & Loading	Section 17.46				
Signs	Section 17.48				
Specific Land Uses	Section 17.50				
Notes:					
1 Projects shall follow all requirements listed except where modified by this specific plan. In the event of conflict between the Zoning Code and this specific plan, the requirements of this specific plan shall control, per Section 17.12.020.D.					

17.37.070 - Scale Standards

These standards are intended to:

- Implement the General Plan density (du/ac) and floor area ratio (FAR) values;
- Shape development in a manner that creates a defined public realm and appropriate scale of buildings for a visually appealing community;
- Reduce building massing through setback and stepback requirements that create appropriate transitions to residential neighborhoods;
- Support high-quality architecture and urban design through modulation requirements and variation in façade length; and
- Require appropriate transitions to designated historic resources.

A. Density

1. **Residential Density.** Projects that include residential dwelling units shall not exceed the allowable dwelling units per acre (du/ac) per Figure LASP-5.
 - a. Fractions shall be rounded to the nearest whole number; those at 0.50 shall be rounded up.
 - b. For projects utilizing state density bonus, refer to Government Code 65915.
 - c. The maximum is based on total site area. If a street dedication or easement is required, density shall be calculated using the size of the lot prior to the street dedication or easement.

B. Intensity

1. **Floor Area Ratio.** Projects that include non- residential space, including mixed-use, shall not exceed the allowable floor area ratio (FAR) per Figure LASP-6.
 - a. In mixed-use projects, residential floor area is included in FAR.
 - b. Areas used exclusively for vehicle and bicycle parking and loading are excluded from FAR.
 - c. The maximum is based on total site area. If a street dedication or easement is required, FAR shall be calculated using the size of the lot prior to the street dedication or easement.

Figure LASP-5: Residential Density



Figure LASP-6: Floor Area Ratio



C. Height

1. **Building Height.** Projects shall not exceed the height limits set in Figure LASP-7.
 - a. Height is measured per [Section 17.40.060](#).
 - b. Maximum height for massing adjacent to street or interior property lines may be limited by required setbacks; see Section 17.37.070.E.
 - c. Exceptions allowed for projecting features such as appurtenances and railings per [Section 17.40.060](#).

D. Setbacks

1. **Street Setbacks.** Buildings shall comply with the street setbacks set in Figure LASP-8. Setback ranges establish a minimum and maximum for the specified percentage of linear street frontage; see Figure LASP-9.
 - a. Street setbacks are measured from the sidewalk line; see Figure LASP-3.
 - b. Minimum setbacks shall apply to all stories of a building; setbacks less than the minimum are prohibited. Maximum setbacks shall apply only to the ground floor.
 - c. Residential units on the ground floor shall have a minimum setback of 5 feet. Where elevated between 4 and 6 feet above sidewalk elevation, a minimum setback of 8 feet shall be required.
 - d. Exceptions allowed per [Section 17.40.160](#) (Table 4-1) and the following: arcades and recessed ground floors up to 15 feet in depth, as well as parking entrances per Section 17.37.100.B, are allowed when a second story meets the specified setback.
 - e. Features allowed within the street setback include: landscaping and planters, hardscape (e.g. stoops, patios), shade structures per Section 17.37.080.D, arcades and galleries per Section 17.37.080.E, walls and fences per Section 17.37.080.G, seating and furniture, outdoor dining, and other open space amenities per review authority approval.

Figure LASP-7: Building Height

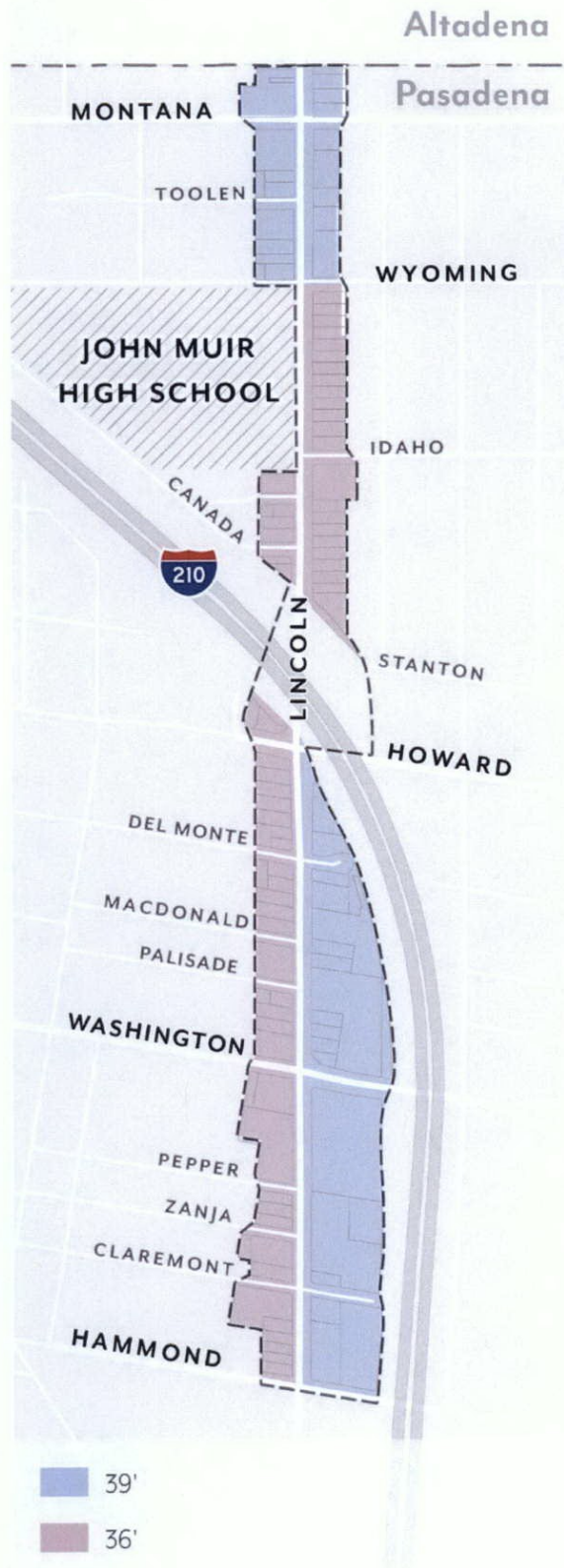

Figure LASP-8: Street Setbacks

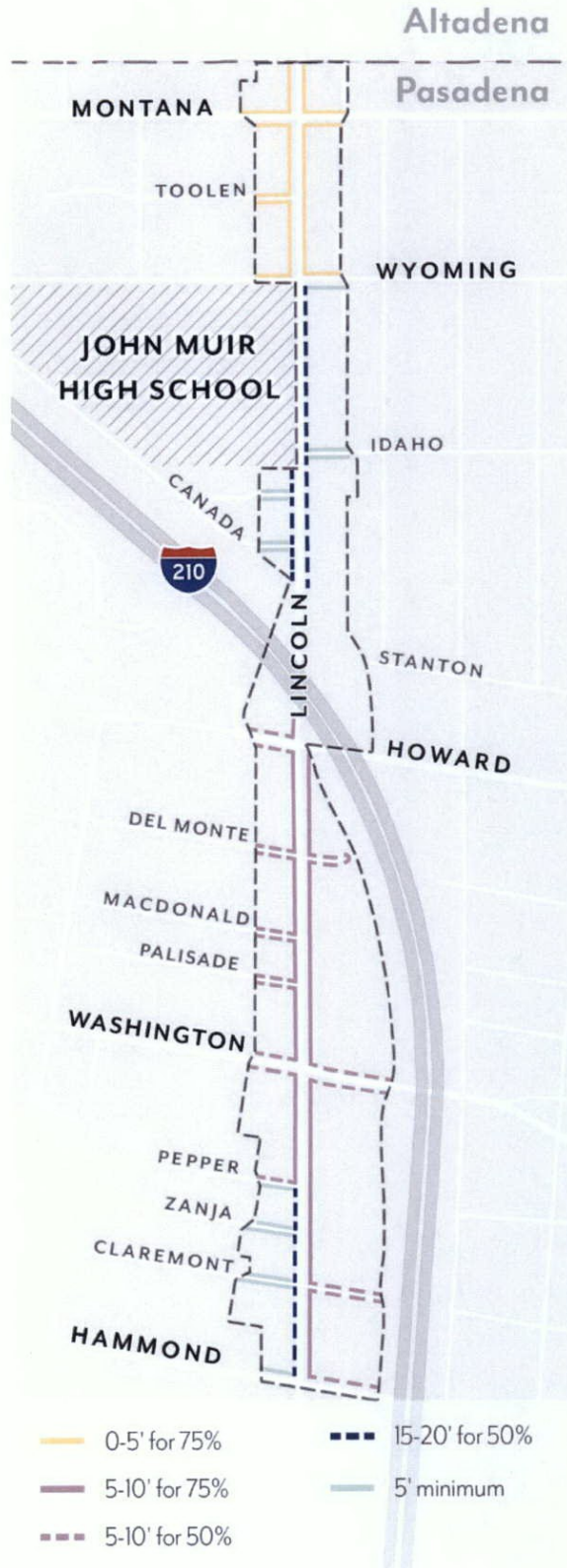
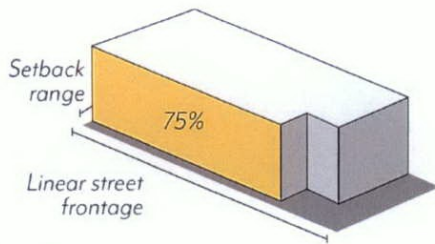

Figure LASP-9: Street Setbacks Percentage



Example condition: When specified for 75%, up to 25% of street frontage can be set back further than the range (percentage varies by street)

Note: Diagrams used for illustrative purposes only.

Figure LASP-10: Street Stepbacks

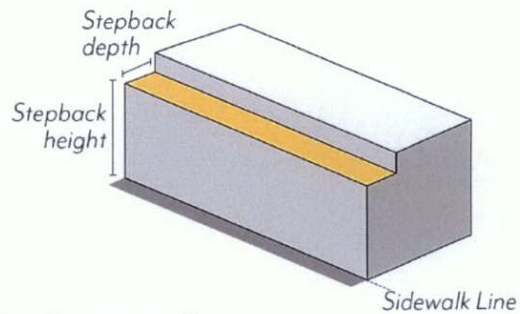

Note: Diagrams used for illustrative purposes only.

2. **Interior Setbacks.** Buildings shall comply with the interior setbacks set in Table LASP-4 based on project type when adjacent to residential zoning districts. No setback is required when adjacent to other districts.

- a. Interior setbacks are those abutting other parcels (non-street side and rear) and are measured from the shared property line.
- b. Exceptions allowed per [Section 17.40.160](#) (Table 4-1).

Table LASP-4: Interior Setbacks Adjacent to RM/RS

Project type	CG, CL, CF	MU-N	RM-16
Mixed-use	15' min.	15' min.	N/A
Nonresidential	15' min.	15' min.	N/A
Residential	N/A	5' min.	5' min.

E. Stepbacks

1. **Street Stepbacks.** Buildings utilizing a height concession per [Section 17.43](#) shall provide a minimum stepback depth of 10 feet by a height of 36 feet along street frontages; see Figure LASP-10.

- a. Street stepbacks are those abutting public right-of-way and are measured from the sidewalk line.
- b. Uses allowed within the street stepback include: private open space (e.g. terraces), shade structures (e.g. trellises), green roofs and photovoltaic panels, and other open space features per review authority approval.

2. **Interior Stepbacks.** Adjacent to RS zoning districts, buildings shall comply with the stepbacks below. Interior stepbacks are not required along other property lines.
 - a. In all zones except LA-RM-16, projects shall not be located within the encroachment plane sloping upward and inward at a 45-degree angle measured from the vertical, commencing 15 feet above the existing grade along the shared property line; see Figure LASP-11.
 - b. In LA-RM-16, projects shall step back a minimum of 15 feet at the second story and 50 feet at the third story, measured from the shared property line; see Figure LASP-11.
 - c. Exceptions allowed per [Section 17.40.160](#) (Table 4-2.1).

Figure LASP-11: Setbacks and Stepbacks

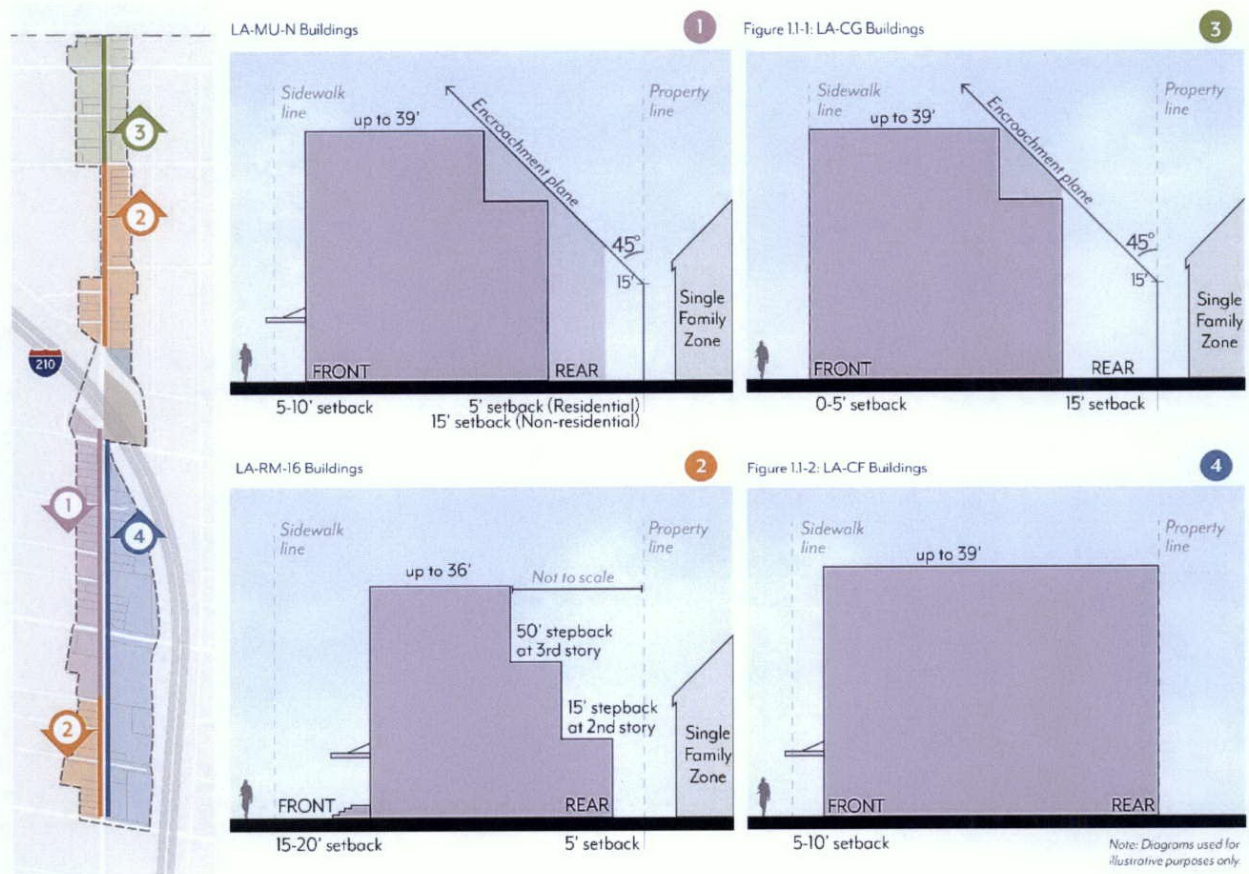

F. Historic Adjacency

1. **Landmark Properties.** Projects on parcels with a historic resource shall be subject to review for consistency with the Secretary of the Interior's Standards.
2. **Transition Massing.** Projects sharing a property line with a designated historic resource are subject to the following modified standards, illustrated in Figure LASP-12.
 - a. **Street Setbacks.** The minimum street setback shall be an average of the minimum setback set in Figure LASP-9 and the established setback of the resource for a minimum of 20 feet from the shared property line. If located between two resources, the street setbacks shall be an average of the setbacks of the two resources for the full street frontage.
 - b. **Interior Setbacks.** The minimum interior setback shall be equal to that of the historic resource or 15 feet, whichever is less. No setback is required where the resource is built to the shared property line.
 - c. **Street Stepbacks.** A maximum streetwall height shall not exceed the height of the historic resource for a minimum of 20 feet from the shared property line. A stepback with a minimum depth of 10 feet is required above this height, measured from the modified minimum street setback.
 - d. **Interior Stepbacks.** Projects shall not be located within an encroachment plane sloping upward and inward at a 30-degree angle measured from the vertical, commencing 15 feet above the existing grade at the property line; see Figure LASP-12. This plane is not applicable if the resource is built to the shared property line.

Figure LASP-12: Historic Adjacency

The 30 degree historic adjacency encroachment plane is an imaginary inclined plane that slopes inward and extends along the length of the shared property line.

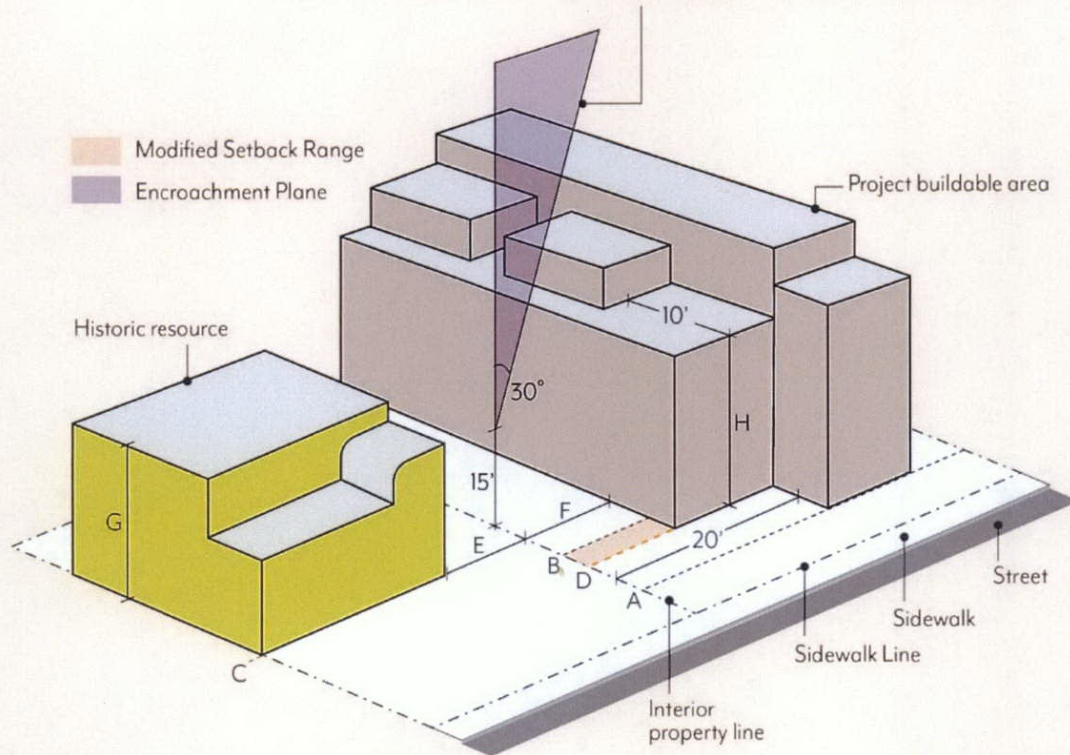

- A: Minimum street setback from setback range
- B: Maximum street setback from setback range
- C: Street setback of historic resource
- D: Modified minimum street setback (average of A & C) within 20' of Interior property line

- E: Interior setback of historic resource
- F: Interior setback of project
- G: Height of historic resource
- H: Maximum height before setback of 10' in depth within 20' of Interior property line

PLAN VIEW

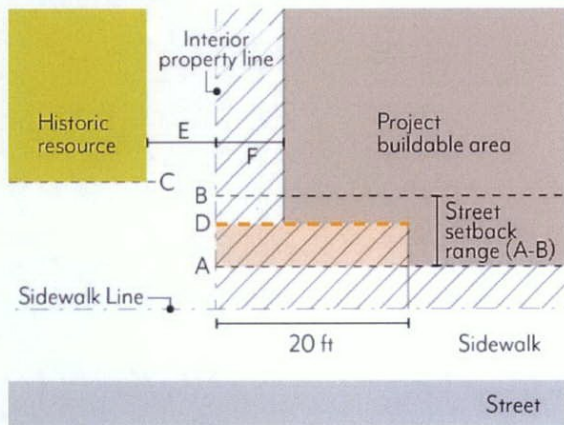

ELEVATION VIEW

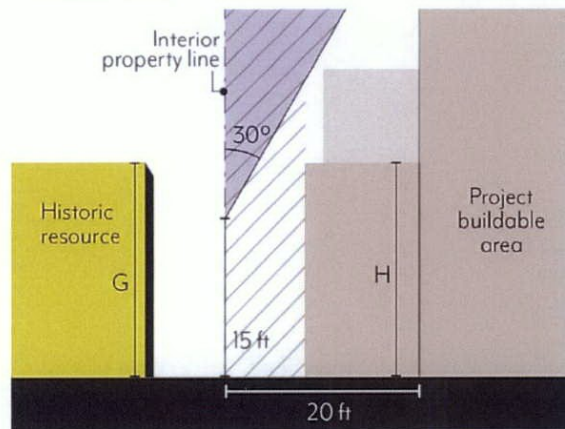

Note: Diagrams used for illustrative purposes only.

G. Modulation

1. **Façade Length.** Each street-facing façade exceeding the length set in Table LASP-5 shall include a minimum break of 10 percent of the façade length or 20 feet, whichever is greater. This break shall be a minimum of 10 feet deep, open to the sky; see Figure LASP-13.

Table LASP-5: Modulation

Façade	CG	CL	CF	MU-N
Length	100'	75'	150'	150'
Area	25%	25%	25%	25%

2. **Façade Area.** Each street-facing façade exceeding 50 feet in length shall modulate a minimum of 25 percent of the area above the ground floor between 2 feet and 12 feet in depth from the primary façade plane; see Figure LASP-14. Buildings with a total of 2 stories or less are exempt.
 - a. The primary façade plane is defined as the vertical plane with the greatest surface area above the ground floor.
 - b. Modulation is not required to be continuous or open to the sky, and may be recessed or projected, but not beyond the sidewalk line.
 - c. Required setbacks (17.37.070.E), façade breaks (17.37.070.G.1), and projected balconies (17.37.080.H.1) shall not count toward the modulation requirement; balconies that are recessed a minimum of 2 feet shall qualify.

Figure LASP-13: Façade Length

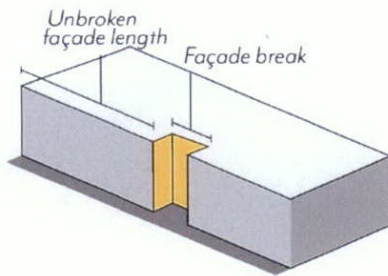

Façades over the specified length shall include a break at least 20 feet wide and 10 feet deep, open to the sky.

Note: Diagrams used for illustrative purposes only.

Figure LASP-14: Façade Area

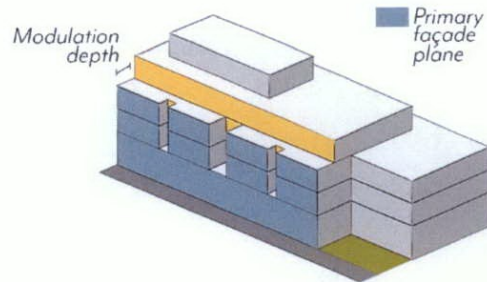

Façades shall modulate a minimum of 25% of the area above the ground floor between 2 and 12 feet in depth.

Note: Diagrams used for illustrative purposes only.

3. Alternative Compliance

a. Eligibility. Modulation standards may be reduced or otherwise modified through the Design Review process if:

- (1) A minimum of 90% of the provided parking is fully or partially subterranean;
- (2) A minimum of one publicly accessible open space is provided at the ground level, visible and accessible from the sidewalk;
- (3) No other concessions, waivers, or incentives have been requested, including those associated with [Section 17.43](#) (Density Bonus), unless the project is designed to achieve LEED Gold certification; and
- (4) The review authority makes all of the following findings.

b. Required Findings

- (1) The building design provides modulation on each street-facing façade in a manner consistent with the project's architectural style and/or immediate context, including adjacent historic resources.
- (2) The building design does not cause an adverse impact on the quality of the ground floor and public realm.
- (3) The ground level open space is of adequate size and integrated with the building in a functional way that ensures the space will be actively utilized.

- (4) The modification will not be detrimental to the health, safety, and welfare of the public.
- (5) The building design is consistent with the objectives and policies of the General Plan and LASP, as well as all other standards of the LASP.

17.37.080 - Frontage Standards

These standards are intended to:

- Prioritize pedestrian access by ensuring doorways are open to a public sidewalk or public open space;
- Increase visibility into ground floor uses to create visual interest for pedestrians;
- Promote shade through arcades and shade structures;
- Support a consistent character when different uses are allowed on the ground floor within the same block;
- Promote consistent ground floor heights when residential and commercial uses are present within the same zone; and
- Limit blank walls on the ground floor to enhance visual interest and pedestrian comfort.

A. Ground Floor

1. **Height.** Buildings facing Lincoln Avenue shall have a minimum ground floor height of 15 feet, measured from the sidewalk elevation to second-story floor or roof of a one-story building; see Figure LASP-15.
 - a. For residential units, the first habitable floor shall be located between 6 feet above and 2 feet below sidewalk elevation.
2. **Depth.** Commercial uses shall have an average interior depth of at least 35 feet and a minimum depth of 20 feet, measured wall-to-wall.

Figure LASP-15: Ground Floor Height

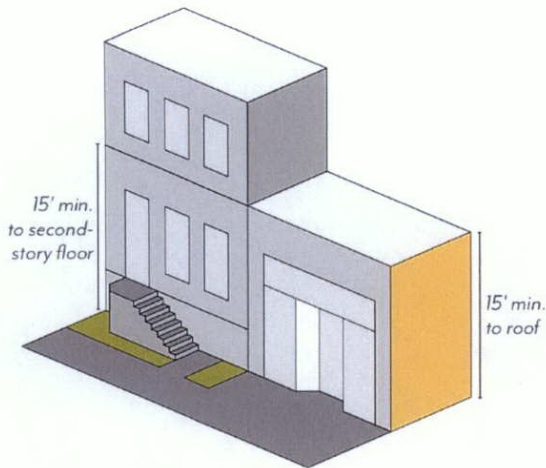

Ground floor height is measured from sidewalk elevation. Ground floor residential units may be sunken or elevated but the second story must start at least 15 feet above sidewalk elevation.

Note: Diagrams used for illustrative purposes only.

B. Entrances

1. **Location.** A minimum of one primary entrance shall be located on the primary frontage of each building and open onto a sidewalk or public space.
 - a. In LA-CG, entrances shall be recessed a minimum of 30 inches from the ground floor building façade along Lincoln Avenue. On other streets, entrances shall be recessed a minimum of 30 inches from the sidewalk line.
 - b. Primary entrances shall be distinguished by architectural features or overhead projections, such as an awning or canopy.
 - c. For non-residential uses, primary entrances shall be located at sidewalk elevation.
 - d. Exception allowed for residential courtyard buildings with unit entrances off the courtyard. Courtyards shall be entered from the street through an architecturally defined entry (covered or open to the sky) or portico.

C. Transparency

1. **Windows & Doors.** Minimum transparency for street-facing façades is set in Tables LASP-6 and LASP-7 based on use.
 - a. For non-residential and residential common space uses, ground floor transparency is measured as the percentage of building frontage that consists of transparent openings between a height of 2 feet and 10 feet above sidewalk elevation.
 - b. All other transparency is measured as the percentage of façade area, viewed in elevation.
 - c. Windows shall be recessed by a minimum of 2 inches from the façade; flush windows may be allowed per review authority approval.
 - d. The use of tinted, mirrored or highly reflective glazing is prohibited.
 - e. Blinds, drapes, posters, and shelving for product displays visible to the public right-of-way shall obscure a maximum of 10 percent of the transparent areas of each respective storefront.

Table LASP-6: Transparency for Non-Residential and Residential Common Space

Transparency	CG	CL	CF	MU-N
Ground Floor	70%	30%	30%	70%
Overall Façade	30%	15%	15%	30%

Table LASP-7: Transparency for Residential Units

Transparency	CG	CL	CF	MU-N
Ground Floor	N/A			15%
Overall Façade	N/A			15%

2. **Blank Walls.** Windowless expanses of street-facing walls shall not exceed 20 feet in length.
3. **Security Bars.** Any exterior or interior security bars shall be designed to be fully hidden from view during business hours with devices such as concealed side pockets and ceiling cavities.

D. Shade Structures

1. **Shading.** Shade structures may project up to two-thirds of the sidewalk width. In LA-CG along Lincoln Avenue, shade structures (e.g. awnings and canopies) are required, subject to a Public Works permit, and shall project a minimum of 5 feet and up to a maximum of 10 feet into the public right-of-way for a minimum of 50 percent of the building frontage.
 - a. Shade structures shall allow a minimum of 8 feet of vertical clearance from sidewalk elevation and shall not conflict with existing trees.
 - b. Shade structures are not required where an arcade or recessed ground floor provides a minimum of 5 feet of unobstructed pedestrian clearance.

E. Arcades & Galleries

1. **Arcades.** Any arcades shall be located behind the minimum setback.
 - a. Arcades shall be a minimum of 8 feet from back of column to building façade.
 - b. The distance between columns shall be at least the same dimension as arcade depth, as measured from the column center.
 - c. The façade shall meet the ground floor transparency set in Section 17.37.080.C.
 - d. Uses allowed within arcades include: pedestrian travel, seating/street furniture, outdoor dining, landscape planters, and/or bicycle parking.
2. **Galleries.** Any galleries shall be located behind the minimum setback.
 - a. Galleries shall allow a minimum of 10 feet of vertical clearance from sidewalk elevation

F. Lighting

1. **Fixtures.** In LA-CG, pedestrian-scale lighting, such as sconces and goose-neck fixtures, shall be located on the building frontage a minimum of every 30 feet along Lincoln Avenue.
 - a. Fixtures shall be placed between 8 and 15 feet above sidewalk elevation, and shall not project more than 30 inches from the façade.

- b. Lighting shall be static; flashing, pulsating or other dynamic lighting is not permitted.

G. Walls & Fences

1. **LA-CG, -CL, -MU-N and -RM-16 Zones.** Walls, fences, raised planters, screening and similar structures (walls/fences) shall be permitted within the required street setback subject to the following conditions. All other walls and fences shall be subject to [Section 17.40.180](#).
 - a. Maximum height shall not exceed 42 inches.
 - b. Walls/fences taller than 30 inches shall be a minimum of 50 percent transparent.
 - c. A minimum 24 inch setback from the sidewalk line is required, separated by planted area; retaining walls with a maximum height of 30 inches are exempt from this requirement.
 - d. Stoops and Patios. Walls along the side of a stoop, patio or entry to a residential dwelling unit shall be set back a minimum of 12 inches from the sidewalk line, separated by planted area.
2. **LA-CF Zone.** Walls/fences located in front of a structure shall be subject to Section 17.37.080.G.1. Walls/ fences not located in front of a structure, but along a street frontage, shall be permitted subject to the following conditions:
 - a. A minimum 5 foot setback from the sidewalk line shall be required, separated by planted area.
 - b. Maximum height shall not exceed 96 inches.
 - (1) Portions of walls/fences greater than 60 inches in height shall be a minimum of 50 percent transparent; portions 60 inches in height or lower are permitted to be solid walls.
 - (2) Solid walls/fences integrated with the building architecture may be permitted to match the height of the ground floor, with a maximum length of 20 feet. Landscaping shall be provided between the solid wall/ fence and the sidewalk line, with the exception for building/property entrances.

3. Exceptions

- a. Exceptions to wall/fence height allowed for guardrails, which may exceed the maximum height to the extent required by the Building Code. The guardrail shall be a minimum of 50 percent transparent.
- b. Exceptions to required wall/fence setback allowed for outdoor dining, which may be enclosed by a wall, fence, or similar structure up to a maximum of 42 inches in height located at the sidewalk line.

H. Balconies & Roof Decks

1. **Balconies.** Balconies may project a maximum of 4 feet into a street setback but shall not extend beyond the sidewalk line or within 6 feet of any interior property line. Balconies shall not project from a building façade within 50 feet of an RS zoning district.
2. **Roof Decks.** Roof decks shall be set back 5 feet from the building edge on all sides, and shall not be located within 50 feet of an RS zoning district. The sum of all roof decks shall not exceed a maximum coverage of 40 percent of the roof area.

17.37.090 - Open Space Standards

These standards are intended to:

- Provide a variety of open space types for gathering, recreation and respite that contribute to enhanced livability within an urban setting;
- Give residents access to natural light and fresh air in and around their living spaces;
- Improve building design and site planning through the integration of open space throughout the development; and
- Correlate open space requirements with number of residents and size of buildings.

A. Minimum Area

1. **Private and Common Open Space.** Projects shall provide the minimum area of Open Space based on use and size. Areas used regularly for parking, loading or storage shall not count towards minimum Open Space requirements.
 - a. Residential. Projects with dwelling units shall provide the minimum area of Open Space per Table LASP-8 as a combination of Private and/or Common Open Space.
 - b. Non-residential. Projects with more than 40,000 square feet of non-residential floor area shall provide a minimum of 5 percent of the gross non-residential floor area as Common Open Space.
 - c. Mixed-use. Projects shall comply with requirements applicable to each type of use.

Table LASP-8: Residential Open Space

Number of Bedrooms	0	1	2	3+
Per Unit, sq ft	200	225	250	275

2. **Publicly Accessible Open Space.** In LA-CF, projects with more than 80,000 square feet of floor area shall provide a percentage of gross floor area as Publicly Accessible Open Space, as set in Table LASP-9.
 - a. Publicly Accessible Open Space shall be provided in addition to Private and Common Open Space requirements.

Table LASP-9: Publicly Accessible Open Space

Project Size (GFA)	80,000-119,999 sq ft	120,000+ sq ft
Per Project, sq ft	2%	3%

B. Private Open Space

1. **Dimensions.** A minimum area of 40 square feet with a minimum dimension of 5 feet in each direction shall be required for Private Open Space.

2. **Distribution.** A maximum of 40 percent of the required residential Open Space set in Table LASP-8 shall be Private Open Space.
 - a. All Private Open Space shall be outdoors.
 - b. Private Open Space may be located within a required setback.

C. Common Open Space

1. **Dimensions.** A minimum area of 400 square feet with a minimum dimension of 15 feet in each direction is required for Common Open Space.
2. **Distribution.** A minimum of 60 percent of the required residential Open Space set in Table LASP-8 shall be Common Open Space shared among tenants.
 - a. A minimum of 70 percent of Common Open Space shall be outdoors, and a minimum of 80 percent of outdoor Common Open Space shall be open to the sky.
 - b. A maximum of 30 percent of Common Open Space may be indoors. Indoor Common Open Space shall not include spaces used primarily for circulation.
3. **Landscape.** A minimum of 25 percent of Common Open Space shall be planted area with a minimum dimension of 30 inches in each direction. Landscaping shall comply with [Section 17.44.050](#).
4. **Trees.** A minimum of one 24-inch box tree per project or for every 500 square feet of outdoor Common Open Space, whichever is greater, shall be planted within the Common Open Space. For projects with 2 or more trees, a minimum of 50 percent of trees planted shall be shade trees.
5. **Hardscape.** A maximum of 25 percent of Common Open Space may be paved in standard concrete. Remaining areas shall use one of the following enhanced paving techniques: brick, natural stone, unit concrete pavers, textured and colored concrete, concrete with exposed or special aggregate. Alternative paving may be allowed per review authority approval.
6. **Water Features.** A maximum of 5 percent of the required Common Open Space shall be fountains, reflecting pools, or other decorative water features. Swimming pools are not considered water features for the purposes of this standard.

7. **Access.** Common Open Spaces may be accessible to the public if desired by the property owner.

D. Publicly Accessible Open Space

1. **Area.** Minimum area requirements are set in Section 17.37.090.A.2, and may be contiguous or noncontiguous, subject to the dimension and elevation standards below.
2. **Dimensions.** A minimum area of 400 square feet with a minimum dimension of 20 feet in each direction is required for Publicly Accessible Open Space.
3. **Access.** A minimum of 50 percent of the Publicly Accessible Open Space shall be accessible to the general public and shall not be restricted to patrons of a particular business.
4. **Signage.** Publicly Accessible Open Space shall have signage visible from the adjacent sidewalk identifying the space as a publicly-accessible amenity and listing accessible hours.
5. **Hours.** At a minimum, Publicly Accessible Open Space shall be open to the general public from 8am to 8pm.
6. **Elevation.** A minimum of 3,000 square feet of Publicly Accessible Open Space shall be at sidewalk elevation. If less square footage is required, then all required Publicly Accessible Open Space shall be at sidewalk elevation.
7. **Hardscape.** A maximum of 25 percent of Publicly Accessible Open Space shall be paved in standard concrete.
 - a. Remaining areas shall use one of the following enhanced paving techniques: brick, natural stone, unit concrete pavers, textured and colored concrete, and concrete with exposed or special aggregate. Alternative paving may be allowed per review authority approval.
8. **Seating.** Seating shall be provided at a minimum of 1 seat per 300 square feet of required Publicly Accessible Open Space.
 - a. Benches shall be calculated as 1 seat per 24 linear inches.
 - b. Fractions shall be rounded down to the nearest whole number.

9. **Landscape.** A minimum of 25 percent of Publicly Accessible Open Space shall be planted area with a minimum dimension of 30 inches in length, width, and depth. Landscaping shall comply with [Section 17.44](#).
10. **Trees.** A minimum of one 24-inch box tree per project or for every 750 square feet of Publicly Accessible Open Space, whichever is greater, shall be planted. For projects with 2 or more trees, a minimum 50 percent of trees planted shall be shade trees.
11. **Common Open Space Credit.** Publicly Accessible Open Space in excess of the minimum may count towards a maximum of 30 percent of the Common Open Space requirement at a 1:1 ratio.

17.37.100 - Parking Standards

These standards are intended to:

- Reduce the visual impacts of parking;
- Regulate appropriate parking supply and location in a manner that prioritizes pedestrian access and multi-modal activity;
- Encourage change of use and adaptive reuse of existing buildings through parking reductions and exemptions;
- Promote a more efficient use of space through shared parking among multiple uses; and
- Increase design standards for parking structures by ensuring habitable floor area and screening between parking and street frontage.

A. Minimum Parking

1. **Number of Spaces.** Projects shall provide off-street automobile parking spaces per Table LASP-10 based on general use classifications.
 - a. Bicycle parking shall be required per [Section 17.46.320](#).

Table LASP-10: Minimum Parking

Use Classification ¹	Number of Spaces	Exceptions
Residential	≤1-bed: 1 per unit ≥2-bed: 1.5 per unit Guest: 1 per 10 units	Guest parking may be shared with commercial parking in mixed-use projects
Recreation, Education & Public Assembly	Section 17.46.040	
Office, Professional & Business Support	2 per 1,000 sq ft in LA-CG; 3 per 1,000 sq ft elsewhere	No parking required for: • First 5,000 sq ft of a project • First 500 sq ft of outdoor dining (per tenant)
Retail Sales (including Restaurants)		
Services		
Industry, Manufacturing & Processing	2 per 1,000 sq ft	Recycling Centers: plus 1 space per bin
Transportation, Communications & Utility	Section 17.46.040	
Other Exceptions		
No new parking required for: • Projects within designated historic resources (excluding additions) • Changes of use in structures built prior to 1970		
Notes:		
1 Use classifications correspond to general use categories in Table LASP-2. The number of spaces listed above shall apply to all uses listed under these general categories, with the exception of specific uses where the parking requirement is lower per Section 17.46.040.		

2. **Shared Parking.** Parking may be shared among multiple uses per [Section 17.46.050](#).
3. **Unbundled Parking.** For any building with new residential units, off-street automobile parking spaces shall be leased or sold separately from the unit rental or purchase fees, such that renters or buyers have the option of renting or buying the residential unit at a lower price than if the parking was included.
 - a. For deed-restricted affordable units, one parking space shall be included in the base rent of each unit. The tenant may choose to receive the parking space or receive a rent discount equivalent to half the amount charged for monthly lease of a parking space. Tenants of affordable units shall not sublease their parking spaces.
 - b. Renters or buyers have the right of first refusal to parking built for their unit. Any remaining spaces may be leased to other users on a month-to-month

basis. New occupants shall have the opportunity to lease or purchase parking built for their unit.

B. Vehicle Access

1. **Driveways.** For Projects with less than 200 feet of primary street frontage, a maximum of 1 two-lane driveway shall be permitted. For sites with more than 200 feet of primary street frontage, a maximum of 2 two-lane driveways shall be permitted.
 - a. Driveways shall be prohibited on primary frontages of 200 feet or less where there is access from a secondary street or alley.
 - b. The Zoning Administrator shall determine the primary frontage.

C. Layout & Design

1. **Surface Parking.** Parking lots shall be set back a minimum of 30 feet from the primary frontage, 10 feet from any secondary frontage, and 5 feet from RS zoning.
 - a. Parking shall be buffered by habitable floor area or landscaped area, except for access and driveways; a minimum of one tree of at least 24 gallons in size shall be provided for every 300 square feet of landscaped area.
 - b. Landscaped area shall be provided as a percentage of surface parking area as follows:
 - (1) 10 to 20 parking spaces: a minimum of 5%.
 - (2) More than 20: a minimum of 10%.
 - c. One tree of at least 24 gallons in size shall be provided for every 6 parking spaces and located so as to visually disrupt long rows of parked vehicles.
 - (1) Trees shall be distributed as evenly as possible throughout the parking area; a maximum of 35% of required trees may be clustered/located within the street setback.
 - d. Landscaping shall include hedges or shrubs with a minimum height of 3 feet at the time of planting that form a continuous visual screen of vehicle headlights.

- e. Landscaping shall be provided between a building and a contiguous parking area per review authority approval.
2. **Podium Parking.** A maximum of 1 story of above- grade parking is permitted within habitable buildings. Multiple stories of above ground parking are permitted if the project meets the parking structure standards below.
3. **Parking Structures.** Structures shall be buffered with habitable floor area between the parking and Lincoln Avenue, except for access and driveways.
 - a. Stand-alone parking structures are prohibited in the LA-MU-N zoning district.
 - b. Elevators and stairs shall be located adjacent sidewalks or public spaces.
 - c. Parking areas shall be screened from the public realm using heavy-gauge metal, precast concrete panels, laminated glass, green walls, photovoltaic panels or other material per review authority approval.
4. **Underground Parking.** Subterranean parking shall be set back a minimum of 5 feet from RS zoning. Otherwise, it may extend up to the property line.

17.37.110 - Definitions

This Section provides definitions of terms and phrases used in this Specific Plan that are technical or specialized or that may not reflect common usage. In case of conflict with other provisions of the Zoning Code, these definitions shall control for the purposes of this Specific Plan. If a word is not defined in this Chapter, the Zoning Administrator shall determine the correct definition.

Amenity Zone. The portion of the sidewalk located above and adjacent to the curb, providing space for amenities such as parkways, outdoor dining, seating, trees, lighting, bicycle racks, bus stops, etc.

Building Frontage. The horizontal distance, measured at grade, of building wall facing the street.

Building Frontage Zone. The portion of the sidewalk immediately adjacent to the building façade, providing space for planters, outdoor dining, sidewalk signage, etc. This zone may not be present on every street or block.

Curb Zone. See 'amenity zone'

Façade. Any exterior wall plane of a building, ground level to top of roof.

Floor Area Ratio. Numerical value obtained by dividing the above-ground area of a building or buildings located on a lot by the total area of the lot.

Footprint. The total ground floor area of the combined structures on a site or project area defined by the perimeter of the building(s), including parking structures but excluding parking lots and non-occupancy structures.

Frontage Zone. See 'building frontage zone'

Gross Floor Area (GFA). The total enclosed area of all floors of a building measured to the inside face of the exterior walls including halls, stairways, elevator shafts at each floor level, service and mechanical equipment rooms and basement or attic areas having a height of more than seven feet, but excluding area used exclusively for parking or loading of vehicles or bicycles.

Ground Floor. The first habitable floor of a building closest to sidewalk elevation.

Mixed-Use Project. The combination of commercial and residential uses in the same structure, where the residential component is located either above (vertical mixed-use) or behind (horizontal mixed-use) the non-residential component. Non-residential uses are typically commercial uses.

Open Space. For any form of open space (Common, Publicly Accessible, Private, etc), see Section 6.3 of the Specific Plan.

Parkway. Landscaped or permeable areas located within the amenity zone of the sidewalk.

Paseo. A publicly accessible open space that functions as a pedestrian passageway connecting a public street to another public street, alley, or internal public space. Subject to minimum dimension and design requirements established by the Specific Plan.

Plaza. A publicly accessible open space with access from a public street. Subject to minimum dimension and design requirements established by the Specific Plan.

Primary Curb Line. The face of the predominant curb of an individual block forming the edge of the street.

Residential Common Space. Those portions of a residential use building not dedicated to residential units that provide common services for residents. This may include spaces such as, but is not limited to, lobby or common building entry, leasing center, gyms/exercise space, shared kitchen, recreation center, screening or living room, business center, mail room, or library. These spaces/portions of the building may be permitted on the ground floor where residential units are not permitted subject to Specific Plan standards.

Setback. The horizontal distance by which a structure, parking area, or development feature is required to be separated from the property line or the sidewalk line where applicable. In some cases superseded by Setback range.

Setback, Interior. Non-street side or rear setback measured at a right angle from the nearest point of the property line abutting another parcel or alley to the nearest portion of the structure, excluding any porches.

Setback, Street. Front or street-side setback measured at a right angle from the nearest point of the sidewalk line to the nearest portion of the structure, excluding any porches.

Setback Range. Minimum and maximum horizontal distances by which a structure or development feature is required to be separated from the sidewalk line. This measurement is similar to a “build-to” line.

Sidewalk Line. The line parallel the property line accommodating the required sidewalk width, measured from the curb face. Where a sidewalk width is not specified, the sidewalk line is the property line.

Sidewalk Zones. The three portions of a sidewalk that together comprise the public realm between a building and the street. Sidewalk zones are defined by the Pasadena Street Design Guide and regulated by the Specific Plan.

Shared Property Line. The property line separating adjacent parcels.

Stepback. The horizontal distance by which an upper story structure or development feature is required to be separated from the property line or the sidewalk line where applicable. Regulated above a specified vertical distance.

Street Frontage. The horizontal distance along the street, measured at grade, between property lines (or sidewalk line where applicable) that are perpendicular to the adjacent street.

Streetwall. Any building façade that faces a street within 10 feet of the minimum sidewalk line.

Streetwall Height. The portion of the street-facing building façade that rises from the sidewalk level to the required height without an additional setback or stepback.

Subterranean. The level of a building, inclusive of parking or habitable space, located primarily below the ground level with a top plate of two feet or less above sidewalk elevation.

Transparent Openings. Building openings (windows or doors) or transparent glazing that provide visual access into the structure.

Unbundled Parking. Parking spaces, in any permitted configuration, rented or sold separately from the lease or purchase price.

Walk Zone. The portion of the sidewalk dedicated to pedestrian movement, clear of any obstructions.

EXHIBIT 3

EXHIBIT 3

NEW ZONING DISTRICT MAP LINCOLN AVENUE SPECIFIC PLAN

