



# Ordinance Fact Sheet

**TO:** CITY COUNCIL

**DATE:** JUNE 12, 2006

**FROM:** CITY ATTORNEY

**SUBJECT: AN ORDINANCE AMENDING THE OFFICIAL ZONING MAP OF THE CITY OF PASADENA TO ESTABLISH THE NORTH PASADENA HEIGHTS LANDMARK OVERLAY DISTRICT.**

## TITLE OF PROPOSED ORDINANCE

**AN ORDINANCE OF THE CITY OF PASADENA AMENDING THE OFFICIAL ZONING MAP OF THE CITY OF PASADENA ESTABLISHED BY TITLE 17, ARTICLE 2 (ZONING MAP) OF THE PASADENA MUNICIPAL CODE (NORTH PASADENA HEIGHTS LANDMARK OVERLAY DISTRICT)**

## PURPOSE OF ORDINANCE

This ordinance implements and codifies modifications to the boundaries of certain zoning districts approved by the City Council on March 13, 2006, to establish the North Pasadena Heights Landmark Overlay District.

As requested by Council, this ordinance also restates the Planning Department's position that regulatory review for historic resource protection purposes is limited to work open to public view from a public street or sidewalk, and excludes views from public alleys.

## REASON WHY LEGISLATION IS NEEDED

This legislation is needed to amend the Zoning Map to allow for overly zoning of certain properties for inclusion in the North Pasadena Heights Landmark Overlay District, based on historical characteristics of the structures within the District.

MEETING OF 06/12/2006

AGENDA ITEM NO. 9.A.1.

**PROGRAMS, DEPARTMENTS OR GROUPS AFFECTED**

The Planning and Development Department will implement the proposed ordinance through modifications to the Zoning Map and processing of subsequent building requests on the affected properties.

**FISCAL IMPACT**

There will not be an immediate fiscal impact as a result of this amendment to the Zoning Code. Permitting fees will be collected from any future development proposed on the properties impacted.

**ENVIRONMENTAL DETERMINATION**

The project is exempt from the requirements of the California Environmental Quality Act (CEQA) pursuant to Class 8, Regulatory Actions to Protect the Environment.

Respectfully submitted,

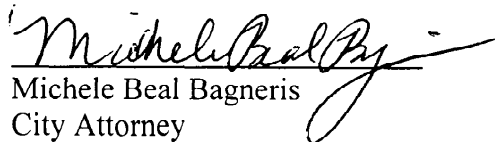
  
Michele Beal Bagneris  
City Attorney

Prepared by:

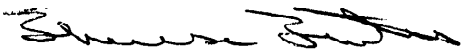
  
Theresa Fuentes  
Deputy City Attorney

Concurred by:

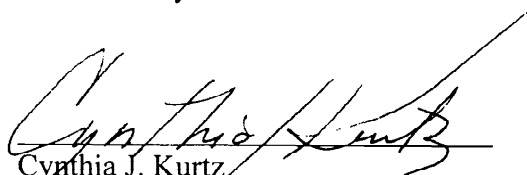
  
Cynthia J. Kurtz  
City Manager

Introduced by: \_\_\_\_\_

ORDINANCE NO. \_\_\_\_\_

**AN ORDINANCE OF THE CITY OF PASADENA AMENDING THE OFFICIAL ZONING MAP OF THE CITY OF PASADENA ESTABLISHED BY TITLE 17, ARTICLE 2 (ZONING MAP) OF THE PASADENA MUNICIPAL CODE (NORTH PASADENA HEIGHTS LANDMARK OVERLAY DISTRICT)**

The People of the City of Pasadena ordain as follows:

**SECTION 1.** This ordinance, due to its length and corresponding cost of publication will be published by title and summary as permitted by Section 508 of the City Charter. The approved summary of this ordinance is as follows:

**“SUMMARY**

This proposed ordinance will amend the official zoning map of the City of Pasadena, and modify the boundaries of certain zoning districts to establish the North Pasadena Heights Landmark Overlay District. Maps showing these modifications are attached to the full text of the ordinance and are on file in the City Clerk’s Office.

Ordinance No. \_\_\_\_\_ shall take effect 30 days from its publication.”

**SECTION 2.** The official zoning map of the City of Pasadena as established by Title 17, Chapter 17.20, Section 17.20.020 of the Pasadena Municipal Code is amended by modifying the boundaries of certain zoning districts established therein as follows:

By reclassifying from the RS-6 (Single-family Residential, 6 units per acre), as shown on the map entitled "North Pasadena Heights Landmark District" attached hereto as Exhibit A and incorporated herein by this reference as if fully set forth herein, and on file in the City Clerk’s office of the City of Pasadena. The legal description attached hereto as Exhibit B, is also on file in the City Clerk’s Office of the City of Pasadena.

**SECTION 3.** Notwithstanding any provision of Title 17 to the contrary, all future construction, exterior alterations, relocations or demolitions in the North Pasadena Heights

Landmark District initiated by application for a building permit, land-use entitlement or building plan check on or after the effective date of this ordinance will require a Certificate of Appropriateness prior to the issuance of any building permits according to the guidelines set forth in the Secretary of the Interior's Standards for Rehabilitation and the Illustrated Guidelines for Rehabilitating Historic Buildings and the Design Guidelines for Historic Districts on file in the City Clerk's Office of the City of Pasadena. Regulatory review is limited to work open to public view from a public street or sidewalk, and excludes views from public alleys.

**SECTION 4.** The City Clerk shall certify the adoption of this ordinance and shall cause this ordinance to be published by title and summary.

**SECTION 5.** This ordinance shall take effect 30 days from its publication.

Signed and approved this \_\_\_\_\_ day of \_\_\_\_\_, 2006.

\_\_\_\_\_  
Bill Bogaard  
Mayor of the City of Pasadena

I HEREBY CERTIFY that the foregoing ordinance was adopted by the City Council of the City of Pasadena at its meeting held \_\_\_\_\_ day of \_\_\_\_\_, 200\_\_, by the following vote:

AYES:

NOES:

ABSENT:

ABSTAIN:

Date Published:

\_\_\_\_\_  
JANE L. RODRIGUEZ, CMC  
CITY CLERK

APPROVED AS TO FORM:



---

Theresa Fuentes  
Deputy City Attorney

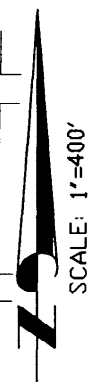
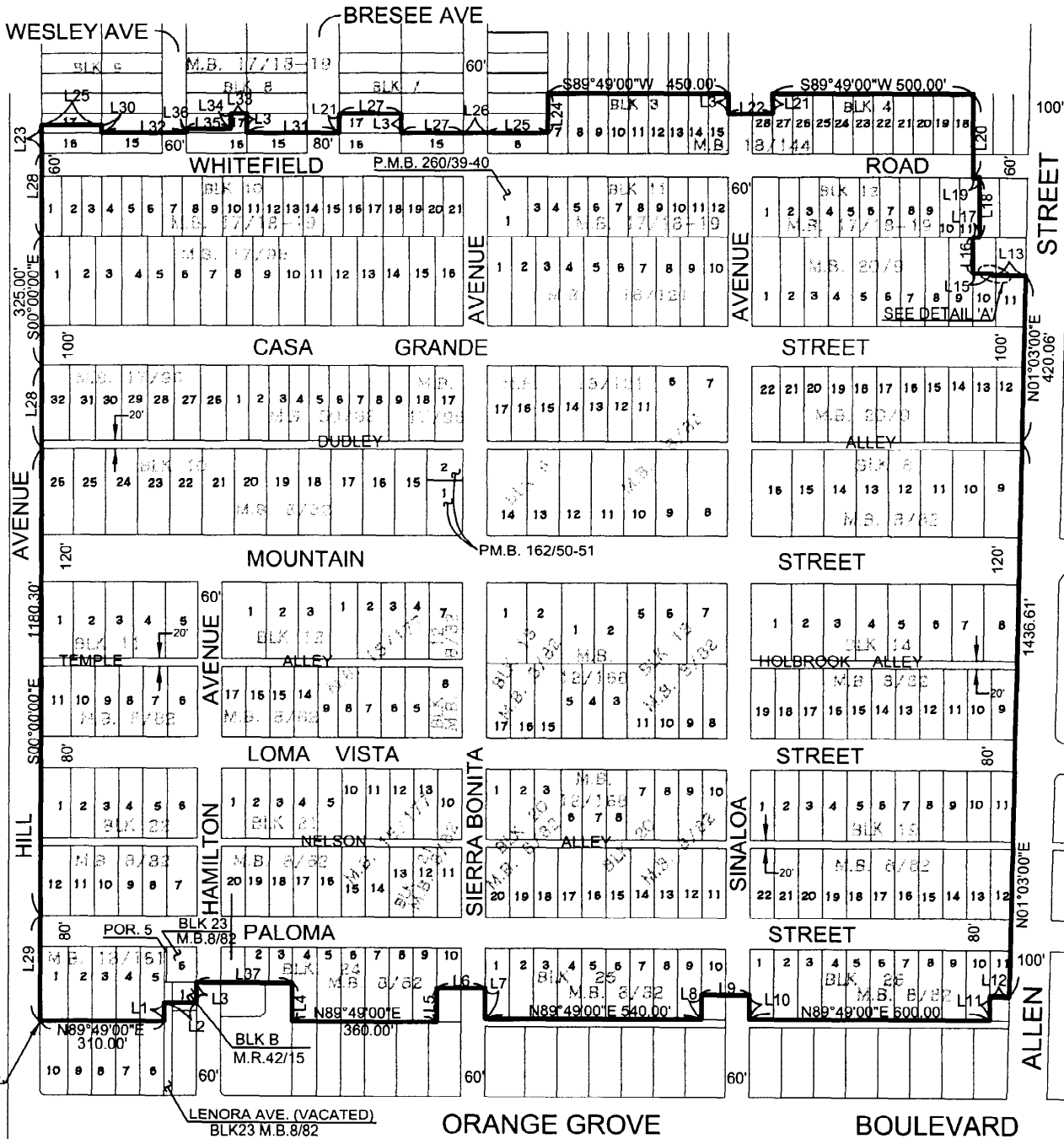

**LEGEND**

P.O.B.

POINT OF BEGINNING



LIMITS OF PROPOSED  
LANDMARK DISTRICT

**EXHIBIT A**



**DAVID EVANS  
AND ASSOCIATES INC.**  
800 North Haven Avenue, Suite 300  
Ontario California 91764  
Phone: 909.481.5750



**PROPOSED  
NORTH PASADENA HEIGHTS  
LANDMARK DISTRICT**

CITY OF PASADENA  
COUNTY OF LOS ANGELES  
STATE OF CALIFORNIA

SHEET NO.	1 OF 2
JOB NO.	PDAX00000067
DRAWN BY:	AJHO
DATE:	04-20-06
SCALE:	1" = 400'

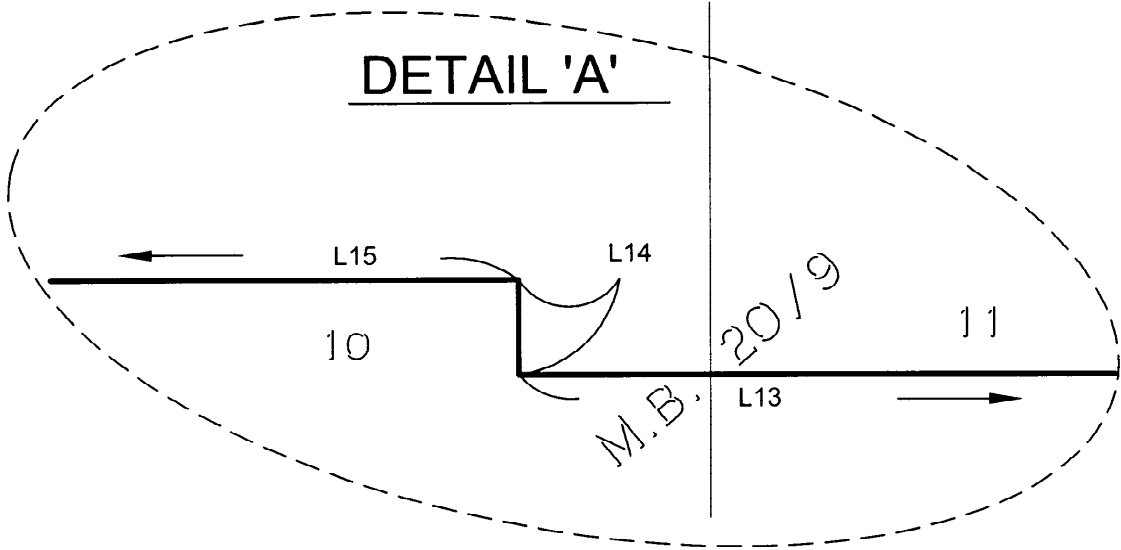

LINE DATA		
LINE	BEARING	DISTANCE
L1	N00°00'00"E	47.83'
L2	N89°49'00"E	80.00'
L3	N00°00'00"E	50.00'
L4	S00°00'00"E	96.73'
L5	N00°00'00"E	86.00'
L6	N89°49'00"E	20.00'
L7	S00°00'00"E	76.00'
L8	N00°00'00"E	61.50'
L9	N89°49'00"E	120.00'
L10	S00°00'00"E	61.50'
L11	N00°00'00"E	56.00'
L12	N89°49'00"E	48.95'
L13	S89°49'00"W	82.47'
L14	N00°00'00"E	5.00'
L15	S89°49'00"W	50.00'
L16	N00°00'00"E	90.00'
L17	N89°49'00"E	17.00'
L18	N00°00'00"E	150.00'
L19	S89°49'00"W	18.10'
L20	N00°00'00"E	210.00'
L21	S00°00'00"E	50.00'
L22	S89°49'00"W	110.00'
L23	S00°00'00"E	70.00'

LINE DATA		
LINE	BEARING	DISTANCE
L24	S00°00'00"E	110.00'
L25	S89°49'00"W	150.00'
L26	S89°49'00"W	60.00'
L27	S89°49'00"W	155.00'
L28	S00°00'00"E	210.00'
L29	S00°00'00"E	266.00'
L30	N00°00'00"E	20.00'
L31	S89°49'00"W	230.00'
L32	S89°49'00"W	210.00'
L33	S89°49'00"W	39.75'
L34	S00°00'00"E	40.00'
L35	S89°49'00"W	110.25'
L36	S00°00'00"E	10.00'
L37	N89°49'00"E	238.00'

**LEGEND**

-  P.O.B.
-  LIMITS OF PROPOSED LANDMARK DISTRICT

**EXHIBIT A**



**DAVID EVANS AND ASSOCIATES INC.**  
 800 North Haven Avenue, Suite 300  
 Ontario California 91764  
 Phone: 909.481.5750

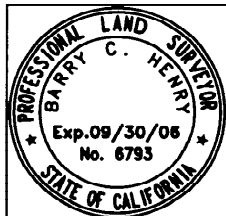

**PROPOSED NORTH PASADENA HEIGHTS LANDMARK DISTRICT**

CITY OF PASADENA  
 COUNTY OF LOS ANGELES  
 STATE OF CALIFORNIA

SHEET NO.	2 OF 2
JOB NO.	PDAX00000067
DRAWN BY:	AJHO
DATE:	04-20-06
SCALE:	1" = 10'

**EXHIBIT B**  
**NORTH PASADENA LANDMARK DISTRICT**

Lots 1 through 5, inclusive, of Tract No. 172 in the City of Pasadena, County of Los Angeles, State of California as per map recorded in Book 13, Page 161 of Maps, in the Office of the County Recorder of said County, that portion of Lot 1 of Block B of the Replat of the Fairmont Tract as per map recorded in Book 42, Page 15 of Miscellaneous Records in said Office of the County Recorder, Lots 9 through 16, inclusive, of Block 8, Lots 6 through 14, inclusive, of Block 9, Lots 15 through 26, inclusive, of Block 10, Lots 1 through 11, inclusive, of Block 11, Lots 1,2,3,7, 8 and 14 through 17, inclusive, of Block 12, Lots 1, 2,15, 16 17 and Lots 5 through 11, inclusive, of Block 13, Lots 1 through 19, inclusive, of Block 14, Lots 1 through 22, inclusive, of Block 19, Lots 1, 2, 3, and 7 through 20, inclusive, of Block 20, Lots 1 through 5, inclusive, 10 through 13, inclusive, and 16 through 20, inclusive, of Block 21, Lots 1 through 12, inclusive, of Block 22, Lot 6 and a portion of Lot 5 of Block 23, Lots 1 through 9, inclusive and a portion of Lot 10 of Block 24, Lots 1 through 9, inclusive and a portion of Lot 10, of Block 25, Lots 1 through 10, inclusive, and a portion of Lot 11 of Block 26, of the Pasadena Heights Tract as per map recorded in Book 8, Page 82 of Maps in said Office of the County Recorder, Lots 1 through 15, inclusive, of Tract No. 735 as per map recorded in Book 15, Page 177 of Maps in said Office of the County Recorder, Lots 1 through 9, inclusive, of Tract No. 4460 as per map recorded in Book 50, Page 33 of Maps in said Office of the County Recorder, Lots 1 through 18, inclusive, and Lots 26 through 32, inclusive, of Tract No. 1088 as per map recorded in Book 17, Page 96 of Maps in said Office of the County Recorder, Lots 15, 16 and 17 of Block 7, Lots 15, 16 and a portion of 17 of Block 8, Lots 15, 16 and a portion of Lot 17 of Block 9, Lots 1 through 21, inclusive, of Block 10, Lots 3 through 12, inclusive, of Block 11 and Lots 1 through 11, inclusive, of Block 12 of the Nazarene University Park Tract as per map recorded in Book 17, Pages 18 and 19 of Maps in said Office of the County Recorder, Lots 1 through 8 of Tract No. 8 as per map recorded in Book 12, Page 168 of Maps in said Office of the County Recorder, Lots 1 through 17, inclusive, of Tract No. 1422 as per map recorded in Book 18, Page 121 of Maps in said Office of the County Recorder, Parcels 1 and 2 of Parcel Map No. 14375 as per map recorded in Book 162, Pages 50 and 51 of Parcel Maps in said Office of the County Recorder, Parcel 1 of Parcel Map No. 23774 as per map recorded in Book 260, Pages 39 and 40 of Parcel Maps in said Office of the County Recorder, Lots 6 through 15, inclusive, of Block 3 and Lots 18 through 27, inclusive, and a portion of Lot 28, of Block 4 of Tract No. 1346 as per map recorded in Book 18, Page 144 of Maps in said Office of the County Recorder, Lots 1 through 9, inclusive, Lots 12 through 22, inclusive, and a portion of Lots 10 and 11 of Tract No. 1209 as per map recorded in Book 20, Page 9 of Maps in said Office of the County Recorder, together with Temple Alley, Dudley Alley, Holbrook Alley and those portions of Lenora Avenue (vacated), Hugus Avenue (vacated), Paloma Street, Hamilton Avenue, Loma Vista Street, Mountain Street, Nelson Alley, Sierra Bonita Avenue, Sinaloa Avenue, Casa Grande Street, Whitefield Road, Wesley Avenue and Bresee Avenue described as a whole as follows:

**Beginning** at the Southwest corner of Lot 1, said point being also on the East line of Hill Avenue (80.00 feet wide) as shown on said Tract No. 172;

Thence along the South line of Lots 1 through 5, inclusive, North 89°49'00" East, 310.00 feet to the Southeast corner of said Lot 5;



Thence along the East line of said Lot 5, North, 47.83 feet to the South line of the North 50.00 feet of vacated Lenora Avenue (40.00 feet wide) as shown on said Pasadena Heights Tract;

Thence along said South line and its Easterly prolongation, North 89°49'00" East, 80.00 feet to the East line of said Lot 1 of Block B, said point being also on the West line of Hamilton Avenue (60.00 feet wide) as shown on said Replat of the Fairmont Tract;

Thence along said East line, North 00°00'00" East, 50.00 feet to the Westerly prolongation of the South line of said Lots 1 through 3, inclusive, of Block 24 of Pasadena Heights Tract;

Thence along said prolongation and said South line, North 89°49'00" East, 238.00 feet to the Southeast corner of said Lot 3;

The along the West line of said Lot 4 of last said tract, South 00°00'00" East, 96.73 feet to the Southwest corner of said Lot 4;

Thence along the South line of Lots 4 through 9, inclusive, of Block 24 of last said tract, North 89°49'00" East, 360.00 feet to the Southeast corner of said Lot 9;

Thence along the East line of said Lot 9, North 00°00'00" East, 86.00 feet to the South line of the North 100.00 feet of Lot 10 of Block 24 of said Pasadena Heights Tract;

Thence along said South line and its Easterly prolongation, North 89°49'00" East, 120.00 feet to the West line of Lot 1, of Block 25 of last said tract, said point being also on the East line of Sierra Bonita Avenue (60.00 feet wide) as shown on said map;

Thence along said West line, South 00°00'00" East, 76.00 feet to the Southwest corner of said Lot 1;

Thence along the South line of Lots 1 through 9, inclusive, of said Block 25, North 89°49'00" East, 540.00 feet to the Southeast corner of said Lot 9;

Thence along the East line of said Lot 9, North 00°00'00" East, 61.50 feet to the South line of the Northerly 114.5 feet of Lot 10, Block 25, of said Pasadena Heights Tract;

Thence along said South line and its Easterly prolongation, North 89°46'00" East, 120.00 feet to the West line of Lot 1, Block 26, of said Pasadena Heights Tract, being also the East line of Sinaloa Avenue (60.00 feet wide) as shown on said Map;

Thence along said West line, South 00°00'00" East, 61.50 feet to the Southwest corner of said Lot 1;

Thence along the South line of Lots 1 through 10, of said Block 26, inclusive, North 89°49'00" East 600.00 feet to the Southeast corner of said Lot 10;

Thence along the East line of said Lot 10, North 00°00'00" East, 56.00 feet to the North line of the Southerly 56.00 feet of Lot 11, Block 26, of said Pasadena Heights Tract;

Thence along said North line, North 89°49'00" East, 48.95 feet to the East line of said Lot 11, being also the West line of Allen Avenue (100.00 feet wide) as shown on said Map;

Thence along said West line, crossing Paloma Street (80.00 feet wide), Nelson Alley (20.00 feet wide), Loma Vista (80.00 feet wide), Holbrook Alley (20.00 feet wide), Mountain Street (120.00 feet wide) and Dudley Alley (20.00 feet wide), North 01°03'00" East, 1436.61 feet to the Northwest corner of said Allen Avenue and said Dudley Alley, all as shown on said Pasadena Heights Tract, said point being also the Southeast corner of Lot 12 as shown on Tract No. 1209;

Thence continuing along said West line, crossing Casa Grande (100.00 feet wide) as shown on said Tract No. 1209, North 01°03'00" East, 420.06 feet to the North line of the South 130.00 feet of Lots 10 and 11 of last said Tract;

Thence along said North line, South 89°49'00" West, 82.47 feet to the East line of the West 50.00 of Lot 10 of said Tract;

Thence along said East line, North 00°00'00" East, 5.00 feet to the South line of the Northerly 90.00 feet of said Lot 10;

Thence along said South line, South 89°49'00" West, 50.00 feet to the West line of said Lot 10;

Thence along said West line, North 00°00'00" East, 90.00 feet to the Northwest corner of said Lot 10, said point being also on the South line of Lot 11 as shown on Nazarene University Park;

Thence along said South line, North 89°49'00" East, 17.00 feet to the Southeast corner of last said Lot 11;

Thence along the East line of said Lot 11, North 00°00'00" East, 150.00 feet to the Northeast corner of said Lot 11 and the South line of Whitefield Road (60.00 feet wide) as shown on last said tract;

Thence along the North line of said Lot 11, South 89°49'00" West, 18.10 feet to the Southerly prolongation of the East line of Lot 18, Block 4, of Tract No. 1346;

Thence along said prolongation and said East line, North 00°00'00" East, 210.00 feet to the Northeast corner of said Lot 18;

Thence along the North line of Lots 18 through 27, inclusive, of said Block 4, South 89°49'00" West, 500.00 feet to the Northwest corner of said Lot 27;

Thence along the West line of said Lot 27, South 00°00'00" East, 50.00 feet to the South line of the North 50.00 feet of Lot 28 of said Block 4;

Thence along said South line and its Westerly prolongation, South 89°49'00" West, 110.00 feet to a point on the West line of Sinaloa Avenue (60.00 feet wide), said point being also on the East line of Lot 15, Block 3, of said Tract No. 1346;

Thence along said East line, North 00°00'00" East, 50.00 feet to the Northeast corner of said Lot 15;

Thence along the North line of Lots 7 through 15, inclusive, of said Block 3, South 89°49'00" West, 450.00 feet to the Northwest corner of said Lot 7;

Thence along the West line of said Lot 7, South 00°00'00" East, 100.00 feet to the Northeast corner of Lot 6, of said Block 3;

Thence along the North line of said Lot 6, South 89°49'00" West, 150.00 feet to Northwest corner of said Lot 6;

Thence crossing Sierra Bonita Avenue (60.00 feet wide), South 89°49'00" West, 60.00 feet to the Northeast corner of Lot 15, Block 7, as shown on said Nazarene University Park Tract, being also the West line of said Sierra Bonita Avenue;

Thence along the North line of said Lot 15, South 89°49'00" West, 155.00 feet to the Northwest corner of said Lot 15;

Thence along the East line of Lot 17 of said Block 7, North 00°00'00" East, 50.00 feet to the Northeast corner of said Lot 17;

Thence along the North line of said Lot 17, South 89°49'00" West, 155.00 to the Northwest corner of said Lot 17, being also the East line of Bresee Avenue (80.00 feet wide) as shown on last said tract;

Thence along the West line of said Lot 17, South 00°00'00" East, 50.00 feet to the Easterly prolongation of the North line of Lot 15, Block 8 of last said tract, said point being also on the East line of said Bresee Avenue;

Thence along said North line and its Easterly prolongation, South 89°49'00" West, 230.00 feet to the Northwest corner of said Lot 15;

Thence along the East line of Lot 17 of said Block 8, North 00°00'00" East, 50.00 feet to the Northeast corner of said Lot 17;

Thence along the North line of said Lot 17, South 89°49'00" West, 39.75 feet to the West line of the East 39.75 feet of said Lot 17;

Thence along said West line, South 00°00'00" East, 40.00 feet to the South line of the North 40.00 feet of said Lot 17;

Thence along said South line, South 89°49'00" West, 110.25 feet to the East line of Wesley Avenue (60.00 feet wide) as shown on said Nazarene University Park Tract, said point being also on the West line of said Lot 17;

Thence along said West line, South 00°00'00" East, 10.00 feet to the Easterly prolongation of the North line of Lot 15, Block 9 of last said tract;

Thence along said North line and its Easterly prolongation, South 89°49'00" West, 210.00 feet to the Northwest corner of said Lot 15;

Thence along the East line of Lot 17 of Block 9, North 00°00'00" East, 20.00 feet to the North line of the South 20.00 feet of said Lot 17;

Thence along said North line, South 89°49'00" West, 150.00 feet to the West line of said Lot 17, said point being also on the East line of said Hill Avenue (width varies) as shown on said Nazarene University Park Tract;

Thence along said East line, South 00°00'00" East, 70.00 feet to the Southwest corner of Lot 16 of Block 9, said point being also on the North line of Whitefield Road (60.00 feet wide), all as shown on said Nazarene University Park Tract;

Thence along the West line of Lot 1, Block 10 of said Tract, and its Northerly prolongation, South 00°00'00" East, 210.00 feet to the Southwest corner of said Lot 1;

Thence along the West line of Lot 1 of Tract No. 1088 and its Southerly prolongation, South 00°00'00" East, 325.00 feet to the Northwest corner of Lot 32, said point being also on the South line of Casa Grande Street (100.00 feet wide), as shown on said Tract No. 1088;

Thence along the West line of said Lot 32 and its Southerly prolongation, South 00°00'00" East, 210.00 feet to the Northwest corner of Lot 26, Block 10, of said Pasadena Heights Tract, being also on the South line of Dudley Alley (20.00 feet wide) as shown on said tract;

Thence along the East line of said Hill Avenue, crossing said Mountain Street, Temple Alley (20.00 feet wide), said Loma Vista Street and said Nelson Alley, South 00°00'00" East, 1180.30 feet to the Southwest corner of Lot 12, Block 22, of said Pasadena Heights Tract, being also on the North line of said Paloma Street;

Thence along the West line of said Lot 1 of said Tract No. 172 and its Northerly prolongation, South 00°00'00" East, 266.00 feet to the **Point of Beginning**.

All as shown on Exhibit "B" attached herewith and made a part hereof.

This real property description has been prepared by me  
or under my direction, in conformance with the Professional  
Land Surveyors Act.

  
Barry C. Henry, P.L.S. 6793  
Expires: 09/30/06

Date: 5/3/06

