

Agenda Report

TO: CITY COUNCIL

Date: MARCH 3, 2008

FROM: CITY MANAGER

SUBJECT: ACCEPTANCE OF AN EASEMENT FOR ACCESS ROAD PURPOSES ON CALIFORNIA INSTITUTE OF TECHNOLOGY PROPERTY

RECOMMENDATION

It is recommended that the City Council adopt a resolution accepting a proposed easement dedication for access road purposes on California Institute of Technology (Caltech) property.

BACKGROUND

As a condition of approval for the Caltech Master Development Plan at 1200 East California Boulevard, Caltech was required to dedicate storm drain and access road easements to the City. A proposed chemistry building in the Caltech Master Development Plan has been located directly over an existing City of Pasadena storm drain line. The Department of Public Works required that the storm drain be relocated around the new building and that new easements be granted. The proposed easement is located in the vicinity of a vacated portion of Michigan Avenue, beginning at Del Mar Boulevard and terminating on the south side of a vacated portion of San Pasqual Street.

The proposed easement document has been prepared by a licensed land surveyor, reviewed by the City Attorney's office and Department of Public Works, and is now ready for approval by the City Council prior to being executed. The property included in the proposed easement is legally described in text and is graphically shown on the attached Department of Public Works Drawing No. 5780, Exhibits A and B.

FISCAL IMPACT

No revenue will be generated by the approval of the dedication. The developer has paid all costs required for preparing and processing the easement.

Respectfully submitted,

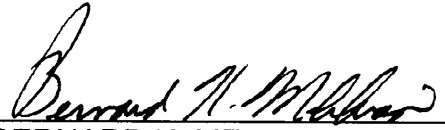

BERNARD K. MELEKIAN
City Manager

Prepared by:

Bonnie L. Hopkins
Principal Engineer

Approved by:

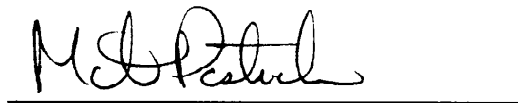
Martin Pastucha, Director
Department of Public Works

RESOLUTION NO.

**A RESOLUTION OF THE CITY COUNCIL OF THE CITY OF PASADENA
ACCEPTING AN ACCESS ROAD EASEMENT ON CALIFORNIA INSTITUTE OF
TECHNOLOGY PROPERTY**

WHEREAS, the access road easement on Caltech property, located in the vicinity of a vacated portion of Michigan Avenue, beginning at Del Mar Boulevard and terminating on the south side of a vacated portion of San Pasqual Street, will allow for the future maintenance of City of Pasadena storm drain facilities, and;

WHEREAS, both the Department of Public Works and the City Attorney's office have reviewed the proposed grant of easement dedication;

NOW, THEREFORE, BE IT RESOLVED by the City Council of the City of Pasadena as follows:

That the presented easement for access road purposes, presented herewith, legally described as Exhibit A and graphically shown as Exhibit B on the Department of Public Works Drawing No. 5780, also presented herewith, is approved and accepted.

Adopted at the regular meeting of the City Council of the City of Pasadena on the _____ day of _____, 2008, by the following vote:

AYES:

NOES:

ABSENT:

ABSTAIN:

JANE L. RODRIGUEZ, City Clerk

Approved as to form:

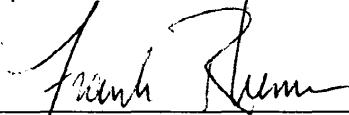

Frank Rhemrev
Assistant City Attorney

EXHIBIT "A"

PARCEL A – ACCESS EASEMENT

1
2
3
4 That portion of Parcel 1 of Parcel Map No. 19340, in the City of Pasadena, County of Los
5 Angeles, State of California, as per map filed in Book 242, Pages 82 and 83 of Parcel
6 Maps, in the office of the County Recorder of said County together with that portion of
7 Michigan Avenue, 60 feet wide, as vacated by the City of Pasadena, in Resolution No.
8 6127, recorded on May 30, 1989 as Instrument No. 89-869499 of Official Records of said
9 County and a portion of Miller Place, as per map filed in Book 54, Page 8 of
10 Miscellaneous Records of said County, described as follows:

11
12 Beginning at the intersection of the centerline of said Michigan Avenue and the easterly
13 prolongation of the southerly right-of-Way line of Del Mar Boulevard, 80 feet wide, as
14 per said vacation of Michigan Avenue by Instrument No. 89-869499; thence easterly
15 along said prolongation, South 89°57'30" East 11.23 feet; thence South 0°04'02" West
16 604.72 feet to the beginning of a curve, concave northeasterly and having a radius of
17 115.01 feet; thence southeasterly 171.31 feet along said curve, through a central angle of
18 85°20'43"; thence South 0°05'32" East 40.00 feet; thence South 89°49'53" West 28.00
19 Feet; thence South 0°10'07" East 340.70 feet; thence North 44°49'53" East 23.03 feet;
20 thence South 45°10'07" East 40.00 feet; thence South 44°49'53" West 40.00 feet; thence
21 North 45°10'07" West 40.00 feet; thence North 0°10'07" West 390.47 feet to the
22 beginning of a curve, concave northeasterly and having a radius of 127.01 feet and to
23 which beginning a radial line bears South 22°56'40" West; thence northwesterly 148.79
24 feet along said curve, through a central angle of 67°07'22"; thence North 0°04'02" East
25 604.71 feet to said easterly prolongation; thence easterly along said prolongation, South
26 89°57'30" East 0.77 feet to the Point of Beginning.

PSOMAS

1
2
3
4
5
6
7
8
9
10
11
12
13
14
15
16
17
18
19
20
21
22
23
24
25
26
27
28
29

This legal description is delineated on accompanying "Exhibit "B" – Parcel A – Access Easement" and is made a part hereof for reference purposes and is not intended to be used in the conveyance of land in violation of the Subdivision Map Act of the State of California.

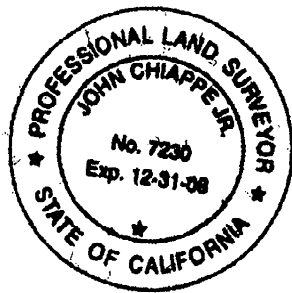

A handwritten signature in black ink, appearing to read "John Chiappe Jr.", written over a horizontal line.

John Chiappe Jr., PLS 7230

PSOMAS

Date: 1/15/2008

EXHIBIT "B"

PARCEL A - ACCESS EASEMENT
 IN THE CITY OF PASADENA
 COUNTY OF LOS ANGELES,
 STATE OF CALIFORNIA
 JOB NO: 1CAL210103/100

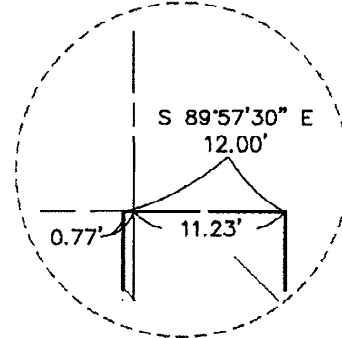

DETAIL
 Not to Scale

LINE TABLE		
LINE	LENGTH	BEARING
L1	23.03'	N44°49'53"E
L2	40.00'	S45°10'07"E
L3	40.00'	S44°49'53"W
L4	40.00'	N45°10'07"W
L5	390.47'	N00°10'07"W
L6	604.71'	N00°04'02"E
L7	12.00'	S89°57'30"E
L8	604.72'	S00°04'02"W
L9	40.00'	S00°05'32"E
L10	28.00'	S89°49'53"W
L11	340.70'	S00°10'07"E

CURVE TABLE			
CURVE	DELTA	RADIUS	LENGTH
C1	67°07'22"	127.01'	148.79'
C2	85°20'43"	115.01'	171.31'

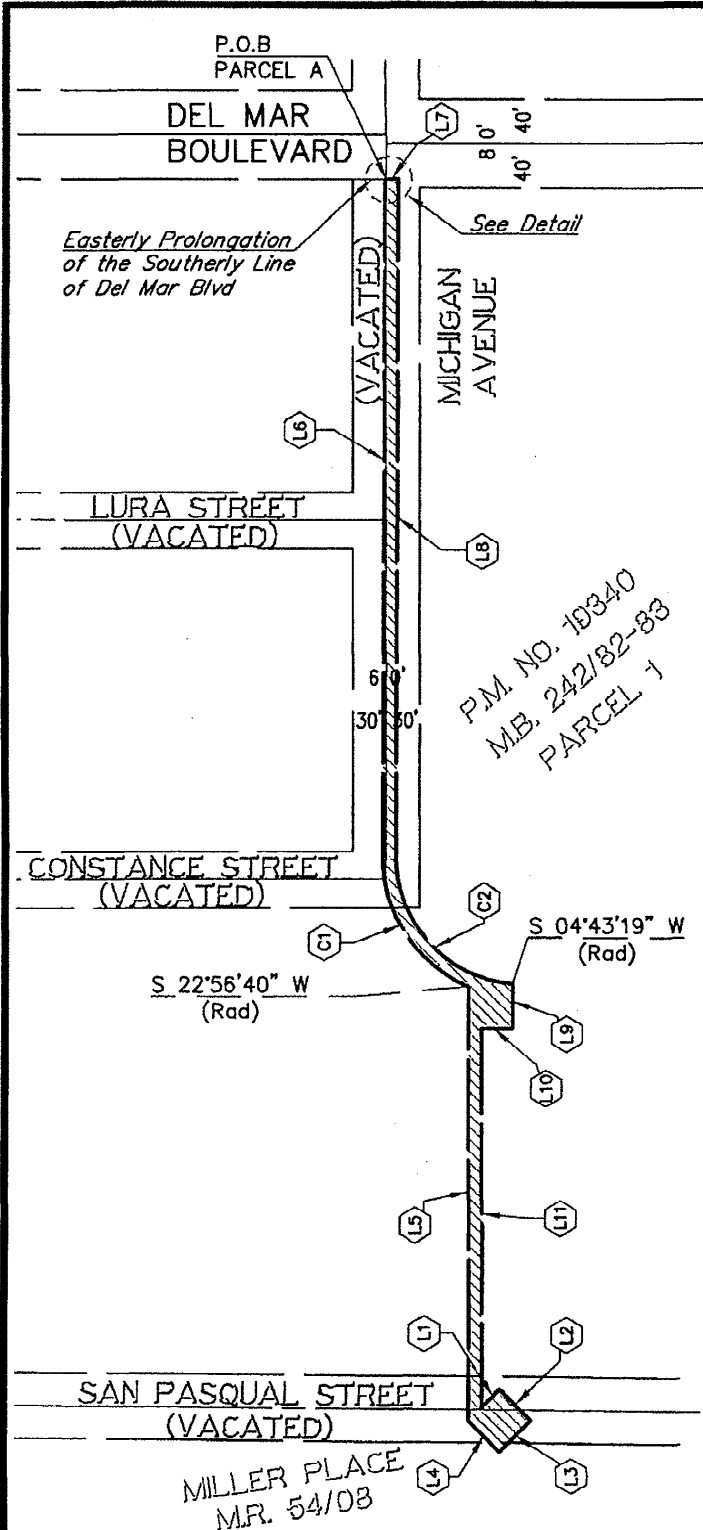

Plotted: 12/21/07 13:36:46 W:\CALTECH\1CAL210103\survey\legals\PLTSH\PL-LEGL-A.dwg kslee

PSOMAS

CITY OF PASADENA - DEPARTMENT OF PUBLIC WORKS

DRAWN BY:
 K SLEE (PRIV)
 DESIGNED BY:
 KSLEE (PRIV)
 CHECKED BY:
 J CHIAPPE (PRIV)
 SUBMITTED BY:
 PSOMAS

LEGAL DESCRIPTION EXHIBIT
 PARCEL A
 ACCESS EASEMENT

APPROVED BY: _____
 CITY ENGINEER RCE NO. 38689 EXPIRES MARCH 31, 2009

DATE _____

SCALE: 1"=160'
 DATE: 12/21/07
 PLAN:
5780
 SHEET 1 OF 1
PL-LEGL-A.DWG 12/28/05