

RESOLUTION NO.

A RESOLUTION OF THE PASADENA CITY COUNCIL
APPROVING THE SUBMISSION OF A PROPOSAL TO THE
NATIONAL FOOTBALL LEAGUE TO RENOVATE AND
MODERNIZE THE ROSE BOWL STADIUM

The City Council of the City of Pasadena hereby resolves as follows:

Section 1. The Rose Bowl Stadium (the "Stadium") was first constructed over eighty years ago with a capacity of 57,000 patrons. Over time, the Stadium has been renovated to enclose the south end of the stadium, expand seating capacity, and to add press boxes and luxury suites, among other changes. However, the Stadium has not been renovated to include amenities currently being offered at state-of-the-art football stadiums. Due to its age, the Stadium is also in need of significant capital maintenance and improvements.

Section 2. Other older stadiums throughout the country are also facing the situation facing the Stadium. For example, the stadium at Ohio State University, which was built in 1922, underwent a \$194 million renovation in 1999. The stadium at the University of Texas, which was built in 1924, underwent a \$95 million renovation also in 1999. The stadium at the University of Wisconsin, which was built in 1917, underwent a \$99 million renovation in 2004 and the stadium at the University of Michigan, which was built in 1928, recently announced plans for a \$200 million renovation.

Section 3. The City has been presented with the opportunity to have a renovation and modernization of the Stadium funded by the National Football League (the "NFL") in conjunction with a lease of the Stadium to an NFL team.

Section 4. The City Council supports the renovation and modernization of the Stadium as well as a lease with the NFL to fund the renovation and to transfer Stadium operational costs to the NFL.

Section 5. The City Council hereby approves the submission of a proposal to the NFL to renovate and modernize the Stadium in general accordance with the conceptual design attached as Exhibit 1 and the principal term sheet attached as Exhibit 2 (together, “the Project”).

Section 6. The Project has been environmentally reviewed pursuant to the provisions of the California Environmental Quality Act (Public Resources Code Section 2100 *et seq.* (“CEQA”), and the State CEQA Guidelines (California Code of Regulations, Title 14, Sections 15000 *et seq.*). An Environmental Impact Report was prepared and the City Council has certified the Final Environmental Impact Report (“FEIR”) in Resolution No. 8474. That resolution is attached hereto as Exhibit 3 and incorporated herein by this reference. The City Council has further added playing field and other recreational improvements to the Project to provide increased recreational opportunities to offset recreational impacts. Those improvements are hereby incorporated as a mitigation measure in Chapter 3.11 of the FEIR as specifically set forth in Exhibit 4. The revised FEIR is hereby recertified as complete with the additional mitigation measure and the findings set forth in Resolution No. 8474 are hereby readopted with regard to the revised FEIR.

Section 7. Based upon the FEIR and the record before the City Council, the City Council finds that the Project will not cause any significant environmental impacts after mitigation except in the areas of Aesthetics, short-term Air Quality impacts during construction,

Cultural Resources, Land Use, Noise, Recreation, and Traffic. Explanations for why the impacts other than those identified in this Section were found to be less than significant are contained in the Environmental Findings set forth in Exhibit 4 to this resolution and are more fully described in the EIR and the Initial Study (included as Appendix A to the FEIR).

Section 8. Based upon the FEIR and the record before the City Council, the City Council finds that the Project will create significant unavoidable impacts to Aesthetics, short term Air Quality during construction, Cultural Resources, Land Use, Noise, Recreation, and Traffic. All feasible mitigation measures for these impacts have been adopted. These significant impacts are further described in the “Findings and Facts In Support of Findings” set forth in Exhibit 4, which is attached hereto and is incorporated herein by reference, and in the FEIR. The changes or alterations required in, or incorporated into, the Project with respect to these impacts, and a brief explanation of the rationale for this finding with regard to the identified impacts, are contained in Exhibit 4. Further explanation for these determinations may be found in the FEIR.

Section 9. The FEIR describes, and the City Council has fully considered, a reasonable range of alternatives to the Project. These alternatives include “Alternative 1 – the No Project Alternative,” “Alternative 2 – the Increased Displacement Events Alternative,” “Alternative 3 – the Alternate Design Alternative,” and “Alternative 4 – the Historic Restoration Alternative.” With respect to each of the alternatives analyzed in the FEIR, the City Council hereby makes the findings set forth in Exhibit 4. The City Council expressly finds that each of the alternatives identified in the FEIR either would not sufficiently achieve the basic objectives of the Project, would do so only with unacceptable adverse environmental impacts, or is not feasible. Accordingly, and for any one of the reasons set forth in Exhibit 4, attached hereto and

incorporated herein by this reference, or set forth in the record, the City Council finds that specific economic, social, or other considerations make infeasible each of the Project alternatives and each is hereby rejected. The City Council further finds that a good faith effort was made to incorporate alternatives into the preparation of the FEIR, and that a reasonable range of alternatives were considered in the review process of the FEIR and the ultimate decision on the Project.

Section 10. For the impacts identified in the FEIR, or otherwise in the record, as “significant and unavoidable,” the City Council hereby adopts the “Statement of Overriding Considerations” set forth in Exhibit 5, which is attached hereto and is hereby incorporated by reference. The City Council finds that each of the overriding benefits, by itself, would justify proceeding with the Project despite any significant and unavoidable impacts identified in the FEIR or asserted to be significant in the record of proceedings.

Section 11. The City Council hereby adopts the mitigation measures set forth in the FEIR and Exhibit 6, attached hereto and incorporated herein by this reference, including the design mitigation, and imposes each mitigation measure as a condition of Project approval. The City Council further adopts the “Mitigation Monitoring and Reporting Program” which is presented as Exhibit 6, attached hereto and incorporated herein by reference. City staff shall implement and monitor the mitigation measures as described in Exhibit 6.

Section 12. The City Clerk shall certify to the adoption of this resolution and shall cause this resolution and her certification to be entered in the Book of Resolutions of the Council of this City.

Adopted at the meeting of the City Council on the 6th day of June 2005, by the

following vote:

AYES:

NOES:

ABSENT:

ABSTAIN:

Jane L. Rodriguez
City Clerk

APPROVED AS TO FORM:

Michele B. Bagneris
City Attorney

Laurence S. Wiener
Special Counsel

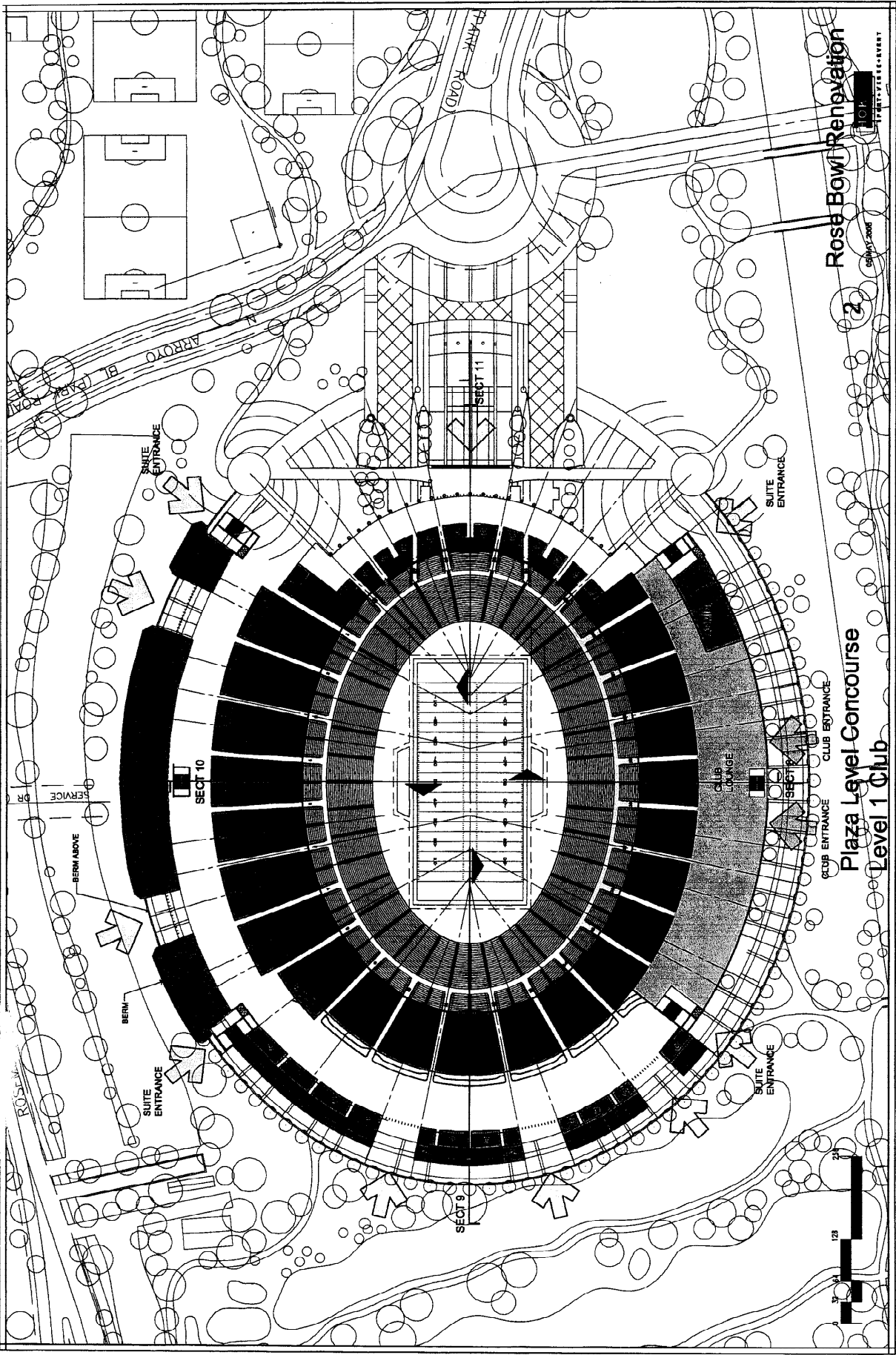

Rose Bowl Renovation

2

Plaza Level-Concourse

Level 1 Club



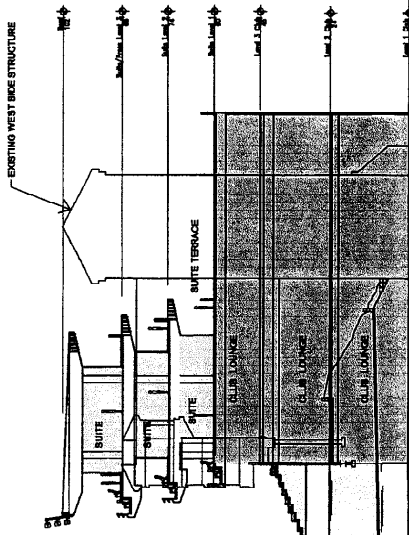

West Side Section @ 50yd Line

Rose Bowl Renovation
05 MAY 2004



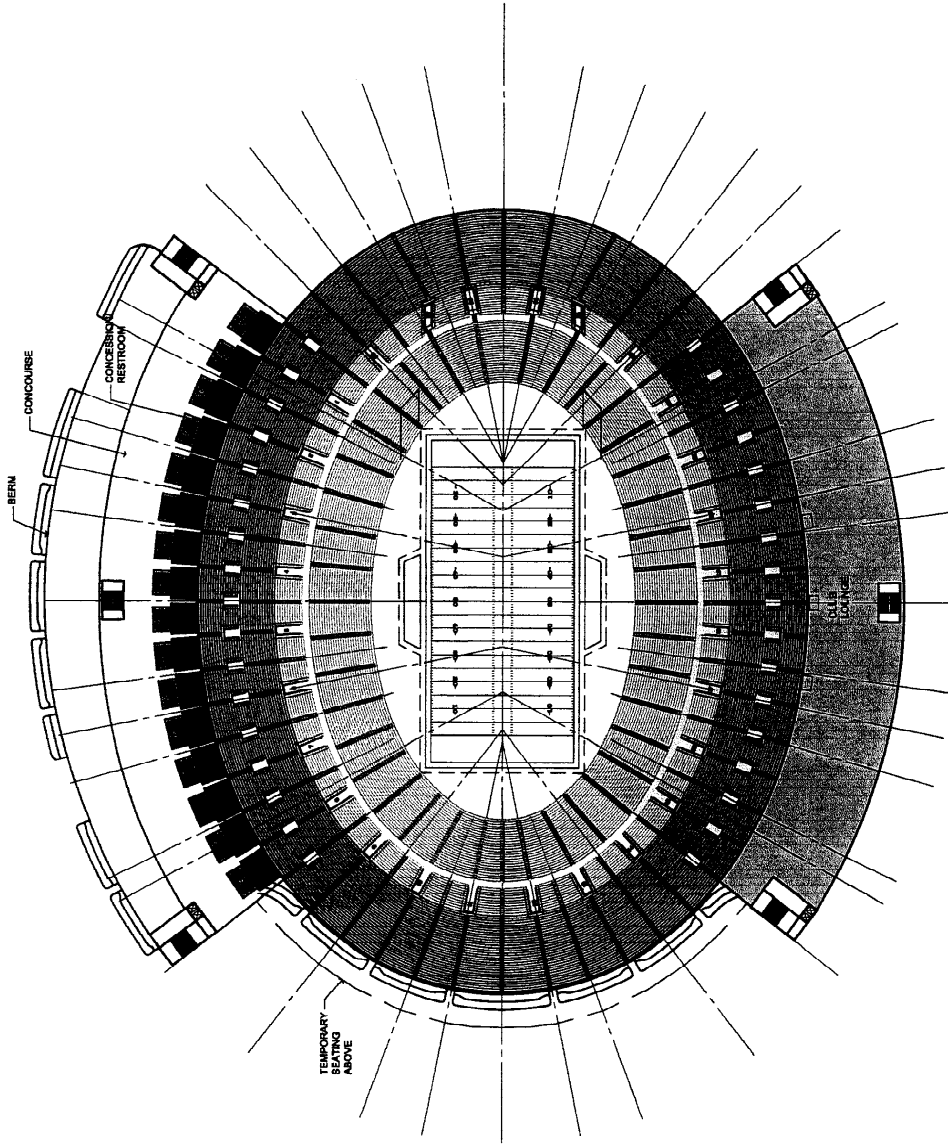

Mid Concourse
Level

4

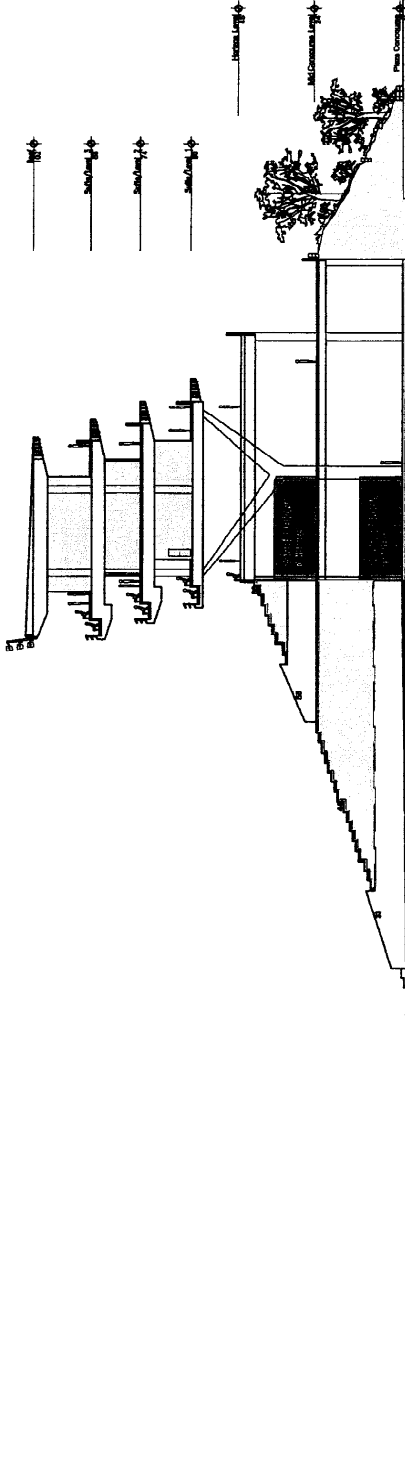

Rose Bowl Renovation
 05 MAY 2005

10



East Side Section @ 50yd Line



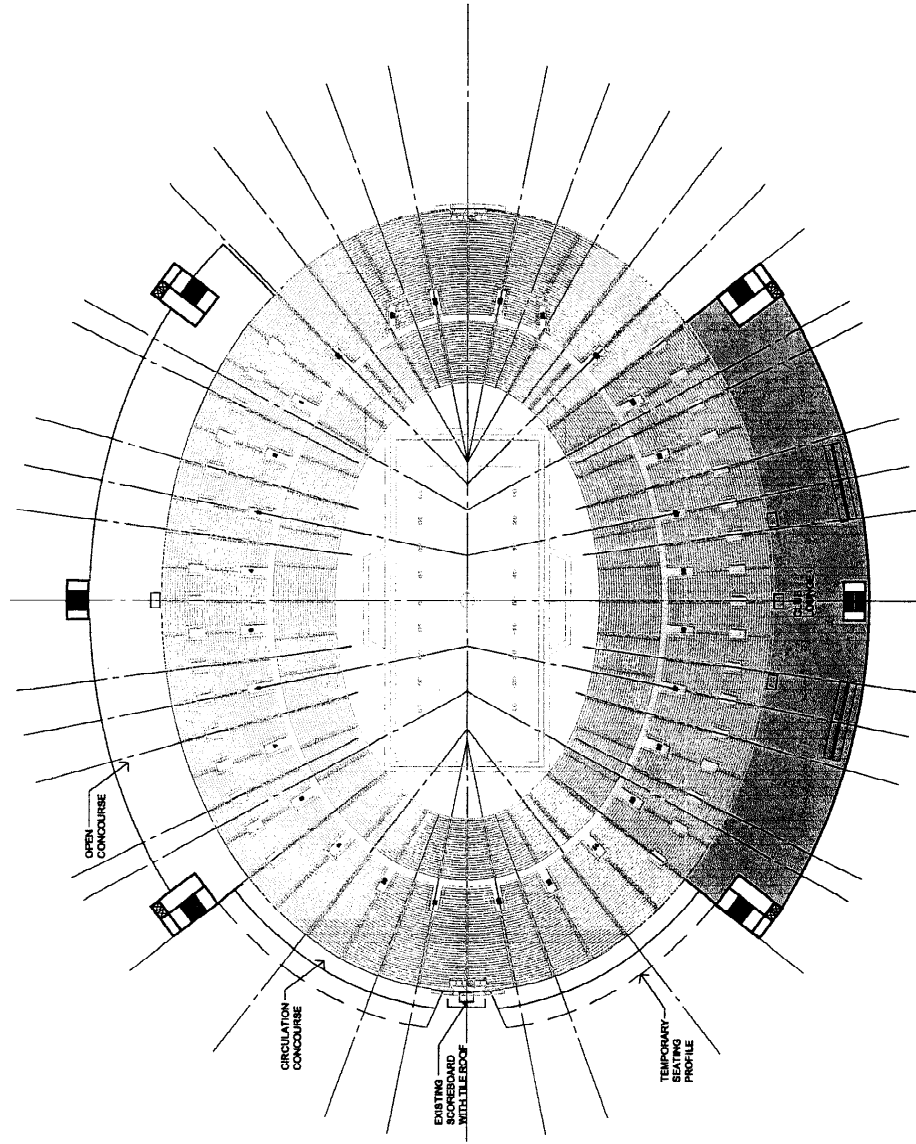

Horizon Level
3 Club

4



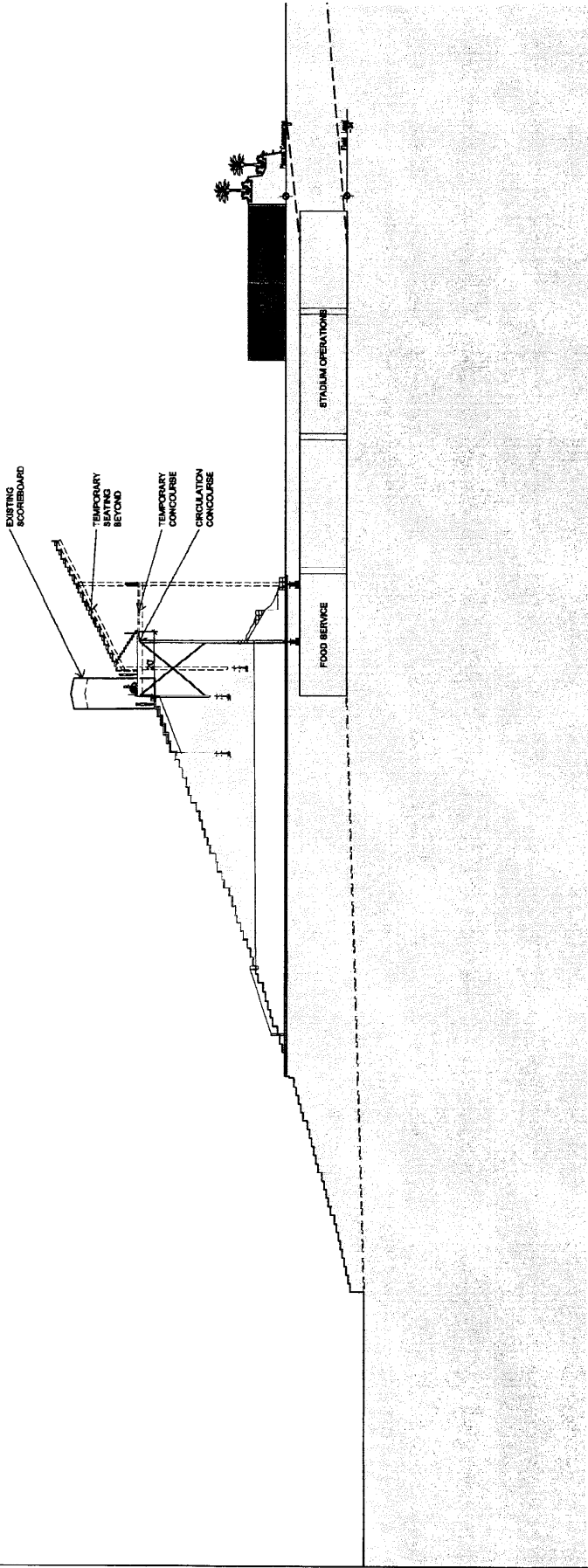

North Endzone Temporary
Seating Section



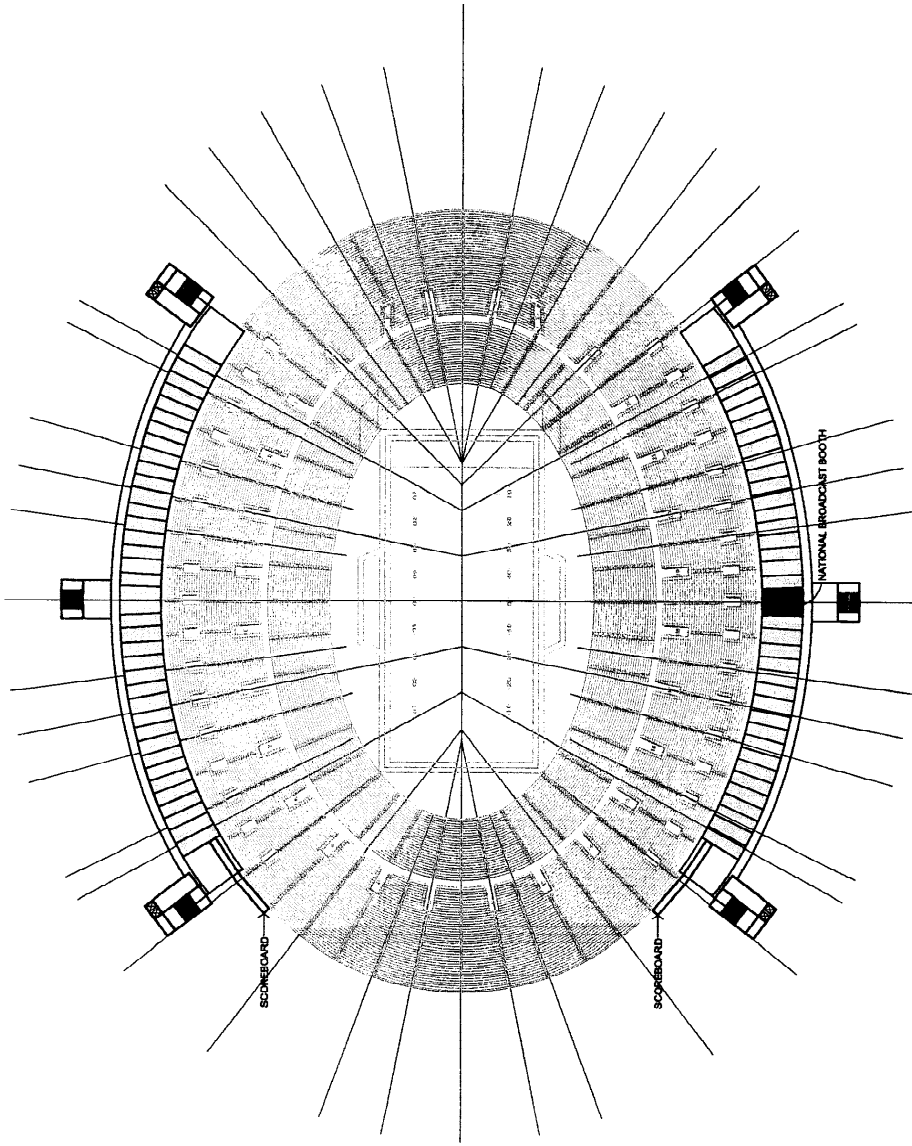

Suite Level 1
74 Suites

5

Rose Bowl Renovation

06 MAY 2006



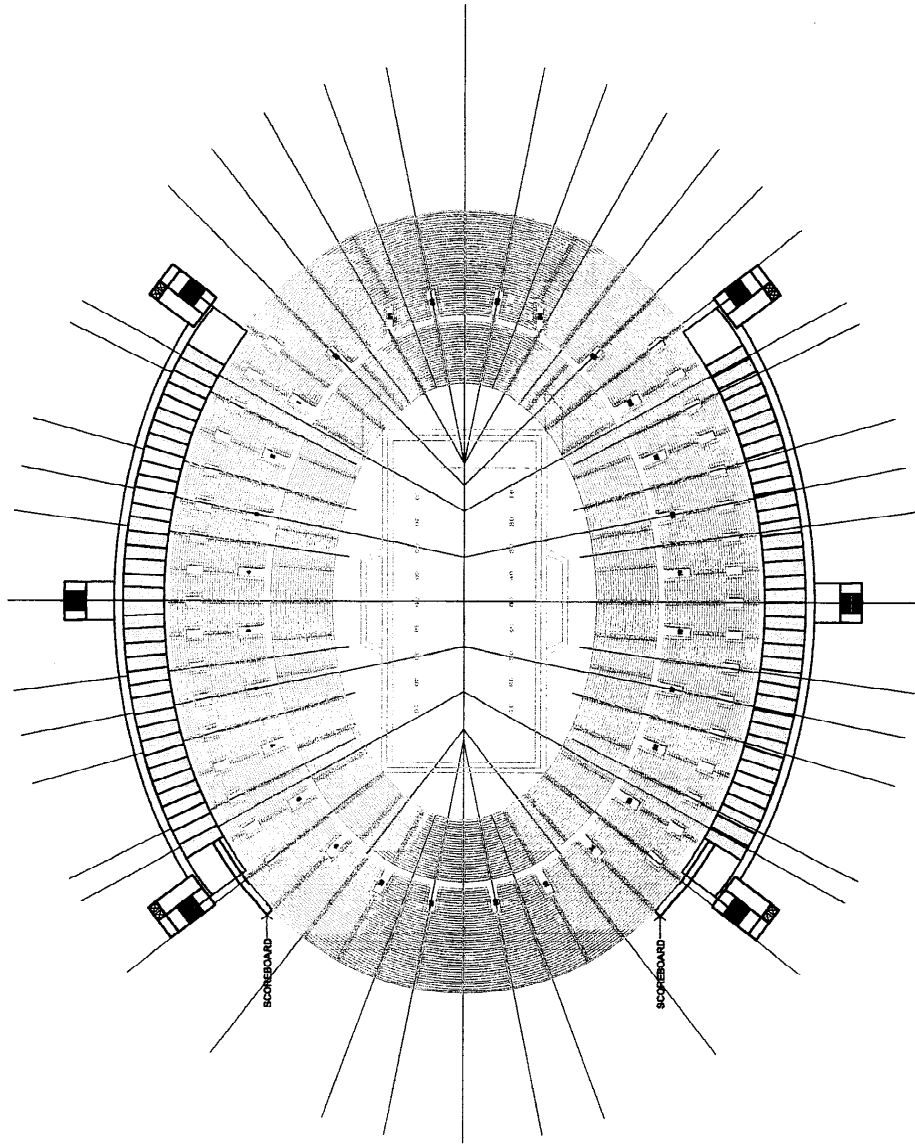

Suite Level 2
74 Suites

6

Rose Bowl Renovation

06 MAY 2006

TOP
 SPORTSVELOCITY.COM

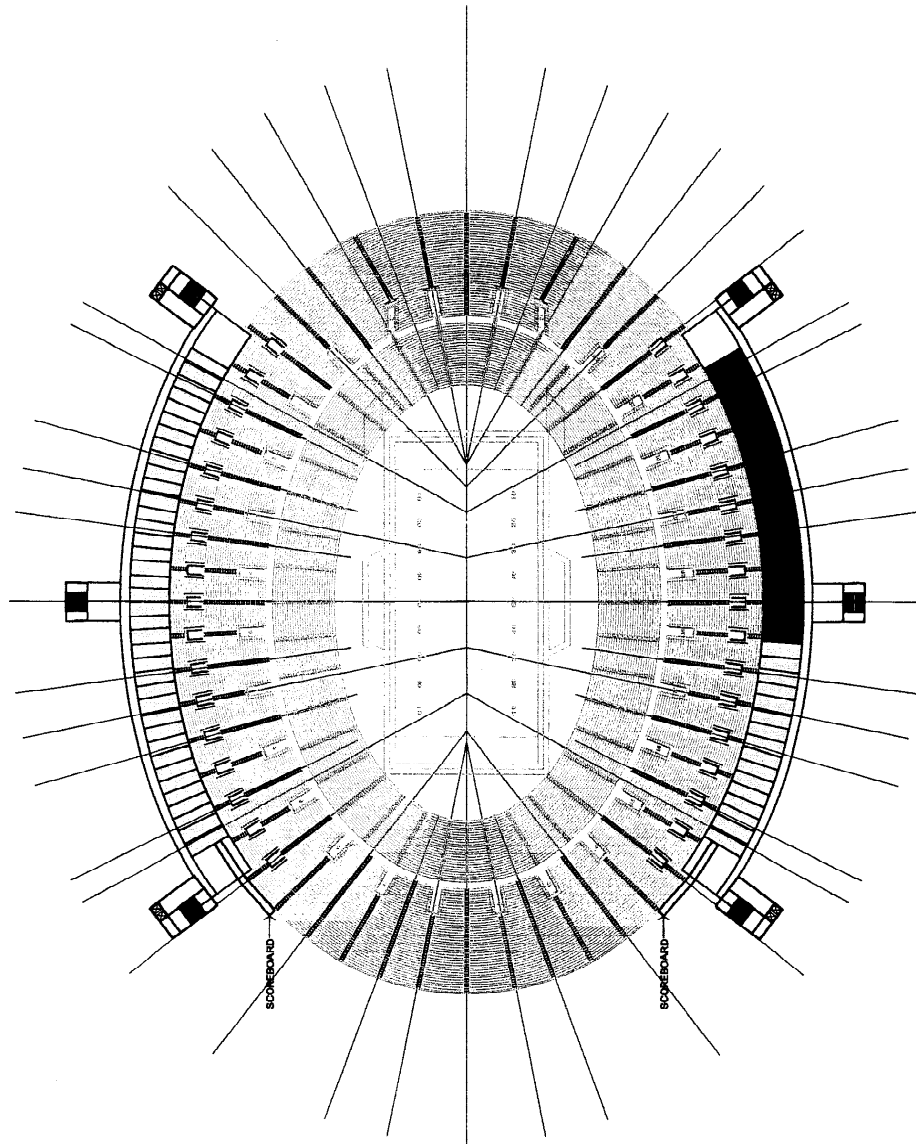

Suite/Press Level 3
54 Suites

7

Rose Bowl Renovation
05 MAY 2006



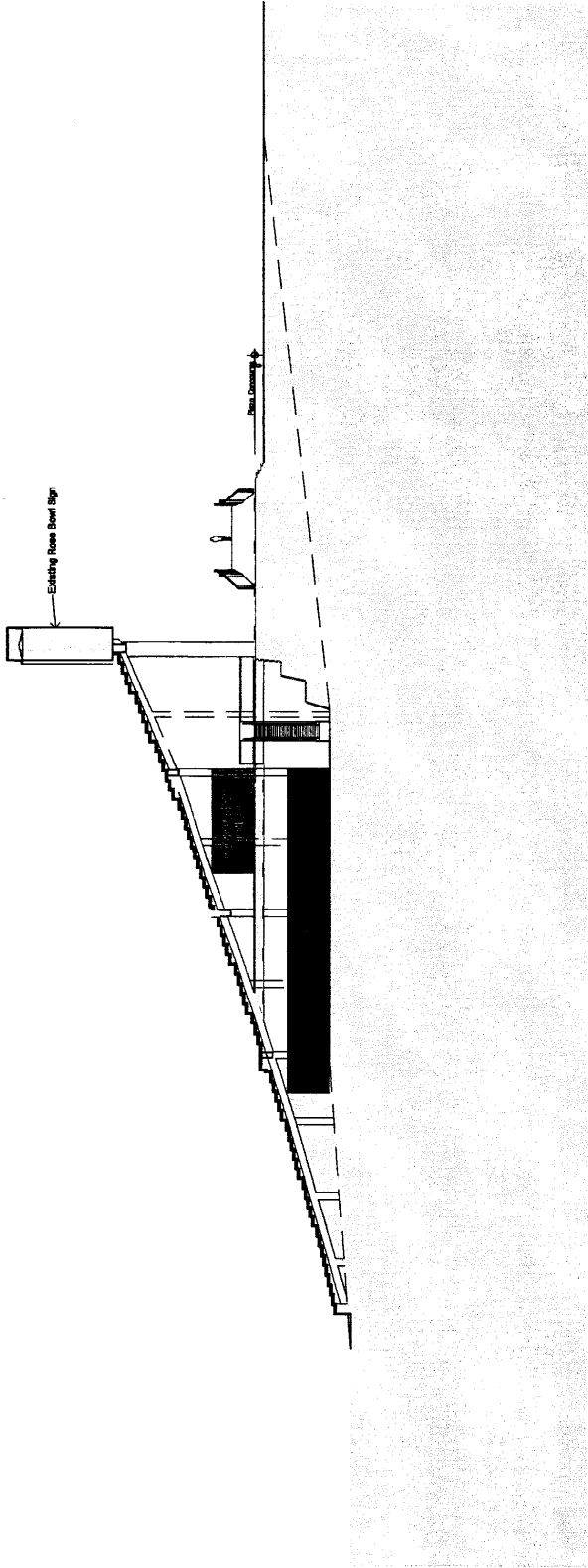

South Endzone Section

